

Revisions
 B-Mar.,1979
 C-Aug.,1979
 D-Sept.,1981
 E-Feb.,1984

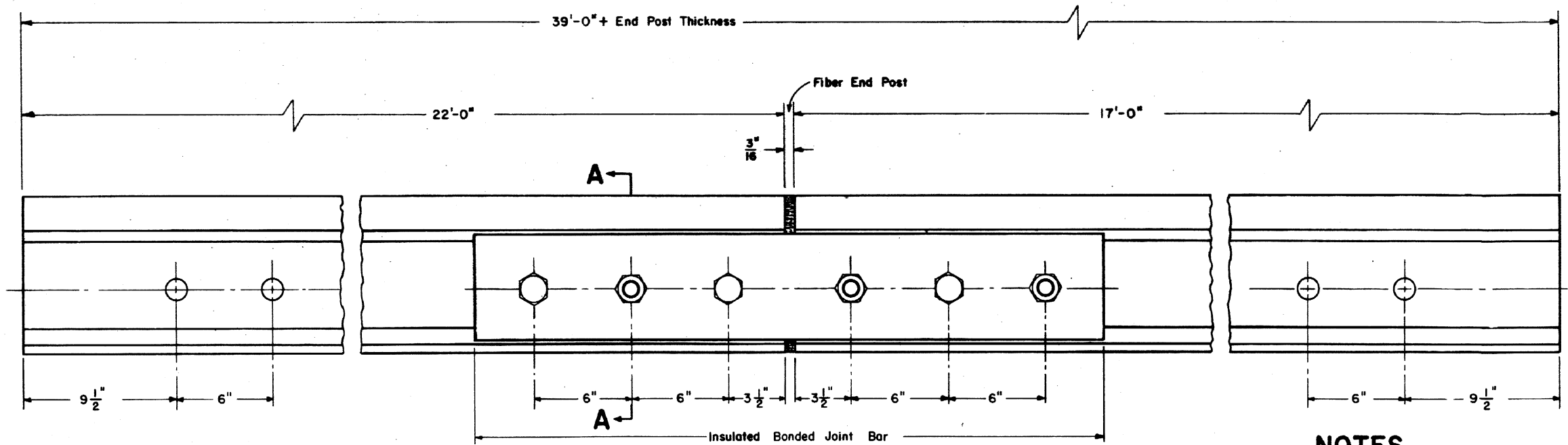

SIDE VIEW

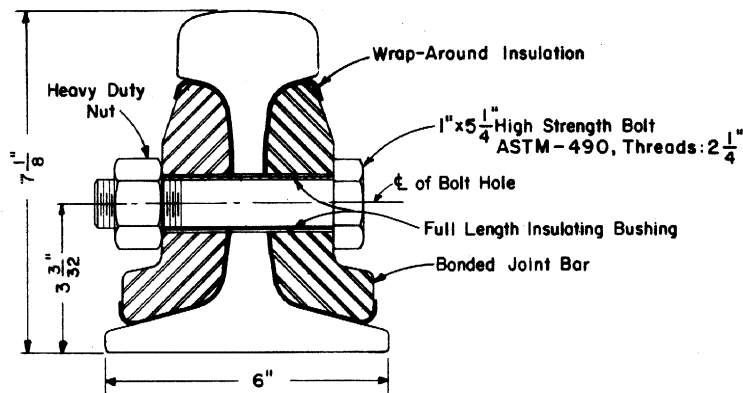

PORTEC INC.

SECTION A-A

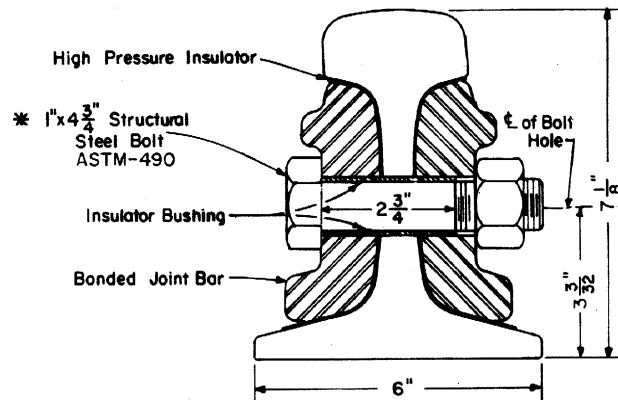

ALLEGHENY DROP FORGE CO.

NOTES

- 1- Refer to AAR Signal Section Part II6.
- 2- All rails to be "End Hardened."
- 3- All bolt holes, in the rail, shall be 1 5/16" dia.
- 4- Bolt heads to be installed in bar, in alternate positions.
- * 5- The Huck Fastener may be substituted for the structural steel bolt in the Allegheny Drop Forge joint.
- 6- When spiking joint, place head in reverse position.

CONRAIL **71370-E**

STANDARD

132 R.E. BONDED INSULATED JOINT

JANUARY, 1978

R.H. Smith
Chief Engineer - Maintenance of Way
C.B. Gordon
Chief Engineering Officer