

JOINT BAR ASSEMBLY
Assemble Joint With Nuts Alternate

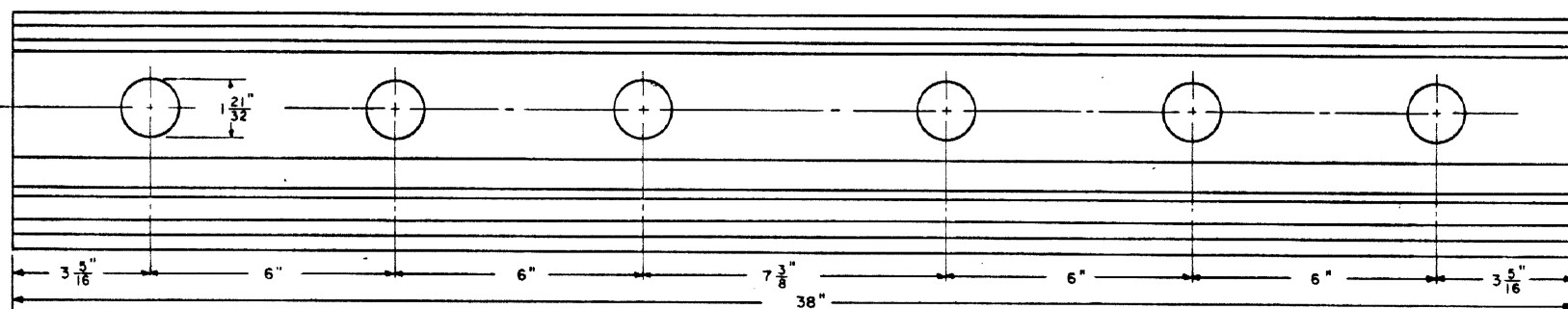

ELEVATION OF JOINT BAR

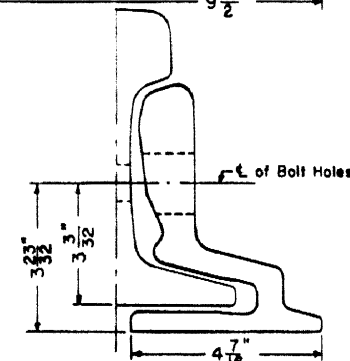
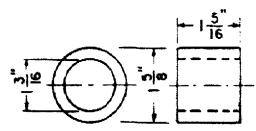

FIBRE BUSHING

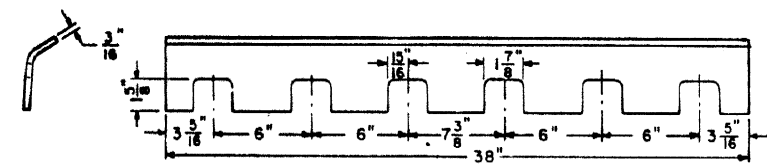

FIBRE HEAD PIECE

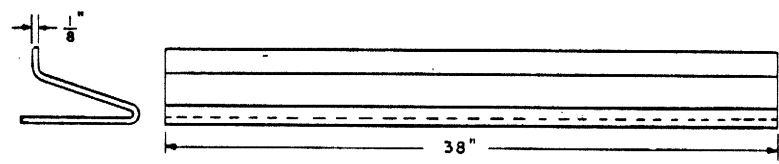

FIBRE BASE PIECE

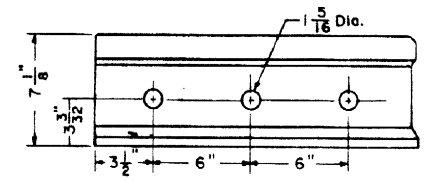

RAIL END DRILLING

NOTE

All fibre parts are furnished by:-
NVF Company-Wilmington, Delaware.

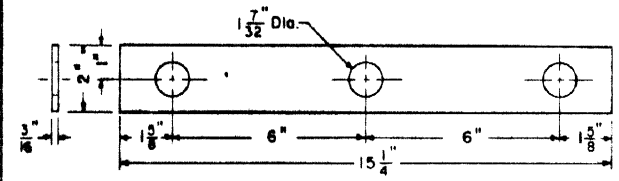

FIBRE WASHER PLATE

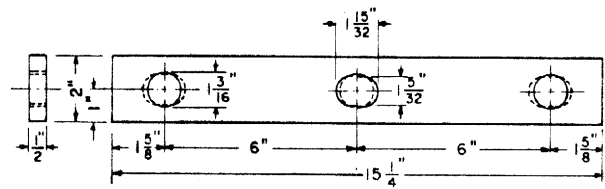

STEEL WASHER PLATE

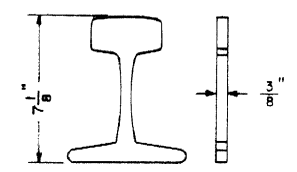

FIBRE END POST

Steel washer plates are to be punched in pairs per solid and dashed lines

CONRAIL 71372-A

STANDARD
CONTINUOUS INSULATING JOINT FOR 132 R.E. RAIL
MANUFACTURED BY PORTEC, INC.
R.H. Smith FEBRUARY, 1978
Chief Engineer-Maintenance of Way