

Revisions  
 B - June, 1992  
 C - Sept., 1994

☒ - These holes in OG Plates only. Location per Plan 73517-().

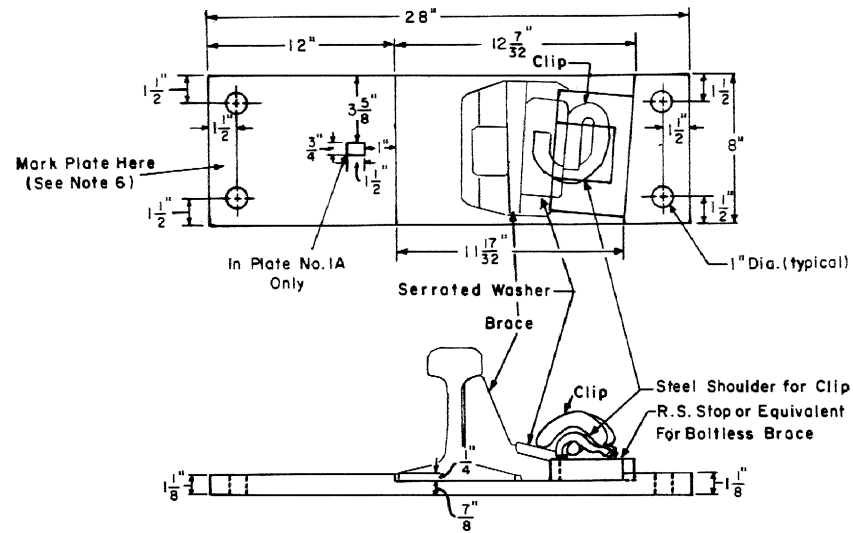

**Nos. IA & I CLIP PLATES**

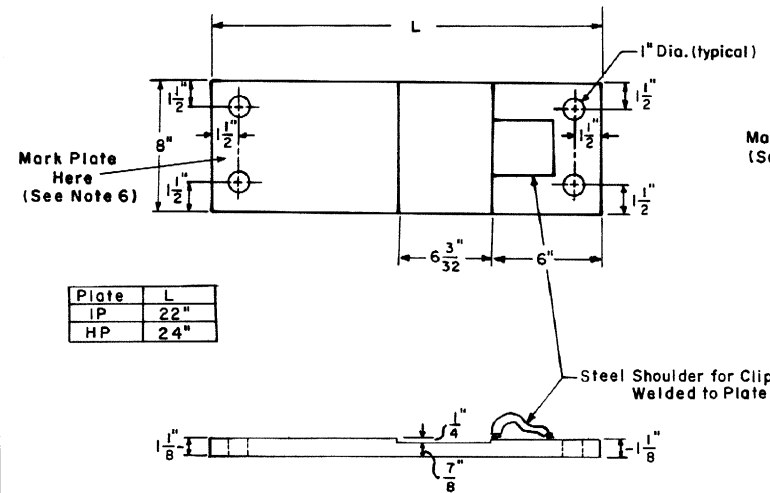
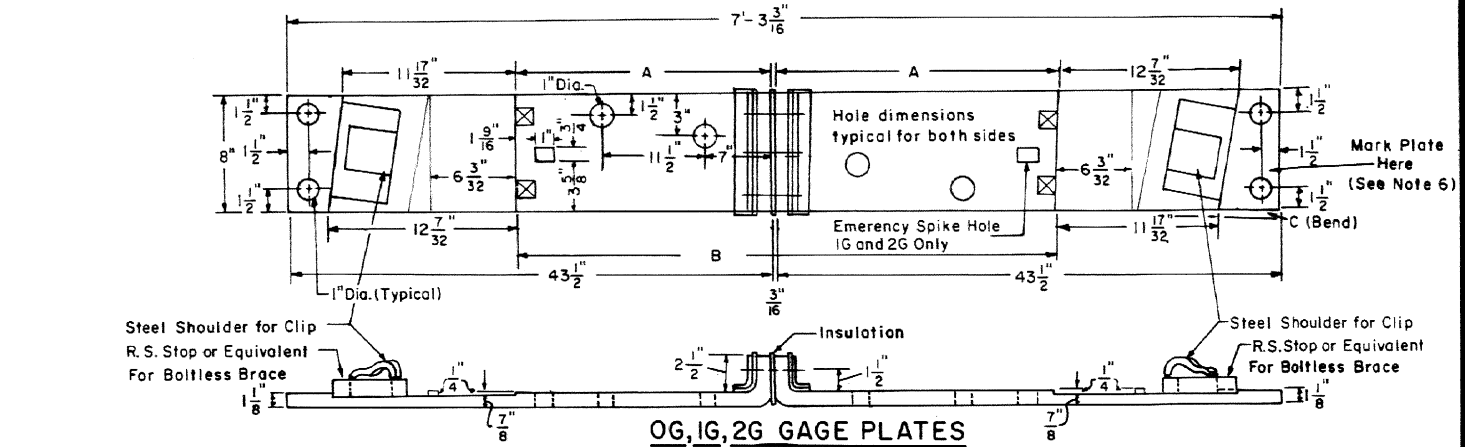

Plate	L
IP	22"
HP	24"

**Nos. IP & HP PLATES**



	38'-0"			59'-6"		
	A	B	C	A	B	C
OG	2'-2 21/32"	4'-5 1/2"	0"	2'-2 21/32"	4'-5 1/2"	0"
IG	2'-2 11/16"	4'-5 9/16"	19 3/32"	2'-2 21/32"	4'-5 1/2"	9 3/32"
2G	2'-2 27/32"	4'-5 7/8"	5 7/8"	2'-2 3/4"	4'-5 11/16"	5 11/16"

	27'-0"		
	A	B	C
IG	2'-2 5/8"	4'-5 7/16"	1 5/16"

**NOTES**

- 1- Plates shall conform to current A.R.E.A. Specifications for Low-Carbon Steel Tie Plates with copper.
- 2- All Gage Plate Bolts shall have A.S.A. Regular Square Heads and A.S.A. Heavy Square Nuts. All Bolts shall be carbon steel with medium carbon steel nuts and conform to current A.R.E.A. Specifications for Heat Treated Carbon Steel Track Bolts and Carbon Steel Nuts.
- 3- All Gage Plate Bolts and insulation (type and location) to be as shown on Conrail Plan 73519-().
- 4- All fiber parts shall conform to current A.A.R. Signal Section Manual, Part 58, Spec. No. 13 for "Hard Fiber" and A.A.R. Signal Section Manual, Part 178.
- 5- Welds must not project beyond vertical face of rail seat.
- 6- Each plate shall be marked by deeply cut characters, not less than one half inch high, in the position indicated on this plan, with plate, switch and rail designation.

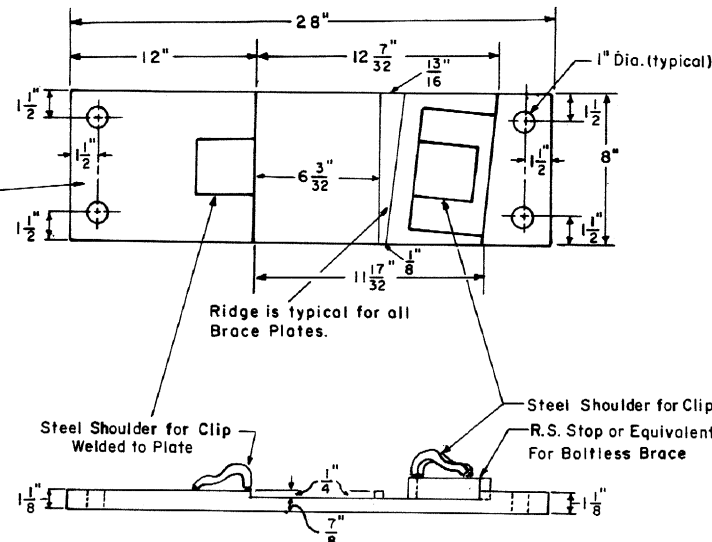

**No. O CLIP PLATE**

**CONRAIL**

**73522-C**

STANDARD

**SWITCH PLATES and GAGE PLATE**

**Nos. 8, 10, 15 and 20 T.O. 132RE / 136RE**

**(PANDROL FASTENERS)**

*W. L. Heide*

Engineer Standards

NOVEMBER, 1991

*R. Millwright*

Chief Engineer