

BUFFALO DIVISION

INDEX

<u>STATION</u>	<u>LOCATION</u>	<u>SHEET</u>
'BC'	• BUFFALO, N.Y.	45
CP-1	BUFFALO, N.Y.	43
CP-5	SENECA YARD, N.Y.	2
47	BUFFALO, N.Y.	39
48	BUFFALO, N.Y.	40
49	BUFFALO, N.Y.	40
CP-55	BLACK ROCK, N.Y.	49
CP-60	WHEATFIELD, N.Y.	53
CP-61	WHEATFIELD, N.Y.	54
CP-79	CAMBRIA, N.Y.	59
CP-80	SANBORN, N.Y.	60
CP-81	NIAGARA, N.Y.	55
CP-82	NIAGARA, N.Y.	56
CP-83	NIAGARA, N.Y.	50
CP-84	SUSPENSION BRIDGE, N.Y.	51
CP-85	SUSPENSION BRIDGE, N.Y.	51
CP-296	BELLE ISLE, N.Y.	3
CP-300	WARNER, N.Y.	4
CP-306	WARNER, N.Y.	5
CP-308	JORDAN, N.Y.	6
CP-313	NORTH PORT BYRON, N.Y.	7
CP-320	SENECA RIVER, N.Y.	8
CP-323	SAVANNAH, N.Y.	9
CP-326	CLYDE, N.Y.	10
CP-329	CLYDE, N.Y.	11

BUFFALO DIVISION

INDEX

<u>STATION</u>	<u>LOCATION</u>	<u>SHEET</u>
CP-334	LYONS, N.Y.	12
CP-335	LYONS, N.Y.	13
CP-340	NEWARK, N.Y.	14
CP-342	NEWARK, N.Y.	15
CP-349	PALMYRA, N.Y.	16
CP-356	WAYNEPORT, N.Y.	17
CP-359	WAYNEPORT, N.Y.	18
CP-362	EAST ROCHESTER, N.Y.	19
CP-367	BRIGHTON, N.Y.	20
CP-369	ROCHESTER, N.Y.	21
CP-371	ROCHESTER, N.Y.	22
CP-373	ROCHESTER, N.Y.	23
CP-380	CHILI, N.Y.	24
CP-382	CHILI, N.Y.	25
CP-388	BERGAN, N.Y.	26
CP-390	BERGAN, N.Y.	27
CP-393	WEST BERGEN, N.Y.	28
CP-402	BATAVIA, N.Y.	29
CP-406	BATAVIA, N.Y.	30
CP-410	WEST BATAVIA, N.Y.	31
CP-415	CORFU, N.Y.	32
CP-417	CRITTENDEN, N.Y.	33
CP-423	WENDE, N.Y.	34
CP-429	DEPEW, N.Y.	35
CP-431	DEPEW, N.Y.	36
CP-433	BUFFALO, N.Y.	37
CP-434	BUFFALO, N.Y.	38

BUFFALO DIVISION

INDEX

<u>STATION</u>	<u>LOCATION</u>	<u>SHEET</u>
CP-438	BUFFALO, N.Y.	41
CP-EL-3	NORTH TONAWANDA, N.Y.	52
CP-'GJ'	EBENEZER, N.Y.	1
CP-GRAVITY	EBENEZER, N.Y.	1
CP-'H'	BLACK ROCK, N.Y.	48
CP-'I'	BLACK ROCK, N.Y.	49
CP-SYCAMORE STREET	BUFFALO, N.Y.	47
CP-'T'	BUFFALO, N.Y.	46
CP-'WD'	THOMPSON, N.Y.	58
'DM'	BUFFALO, N.Y.	62
'EX' (INDUSTRIAL CROSSING)	BUFFALO, N.Y.	42
'FW'	BUFFALO, N.Y.	61
MORTIMER	MORTIMER, N.Y.	57
'RB'	BUFFALO, N.Y.	44

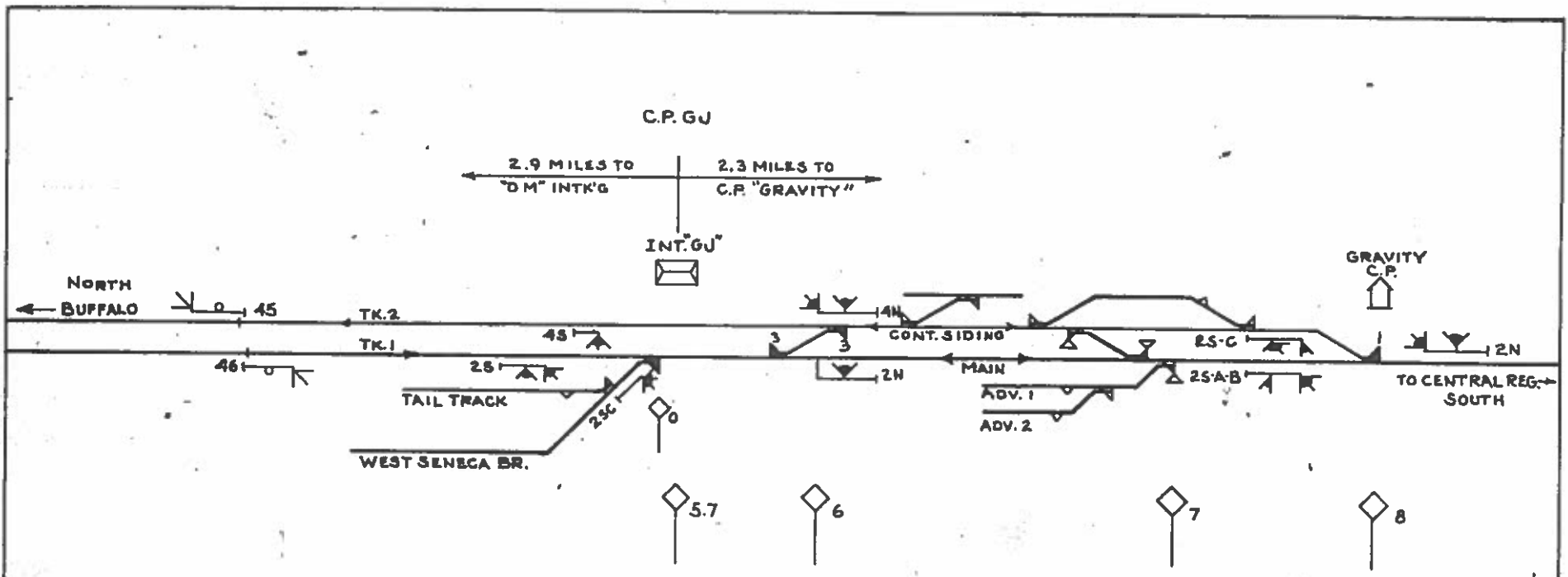

CONRAIL BUFFALO DIV.	C. & S. DEPT.	PHILADELPHIA, PA.
C.P. "GJ" & C.P. GRAVITY HARRISBURG-BUFFALO MAIN LINE EBENEZER, N.Y.		
REV. NO.	1-1-84	PG. 1
SCALE: NONE		

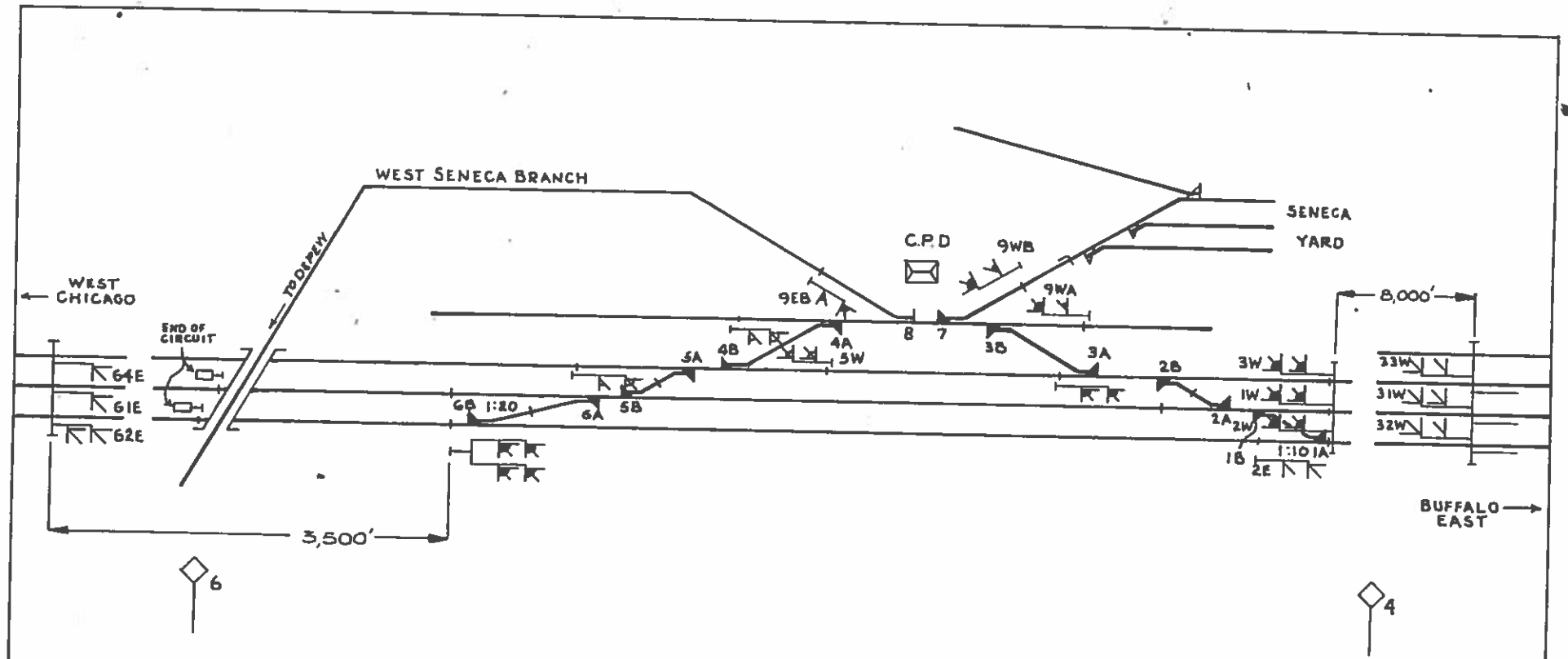

CONRAIL BUFFALO DIV.	C. & S. DEPT	PHILADELPHIA, PA.
C.P. "5" SENECA YARD, N.Y.		
REV. NO.	1-1-4	PG 2
SCALE: NONE		

C.P. 296
CONTROLLED FROM BUFFALO

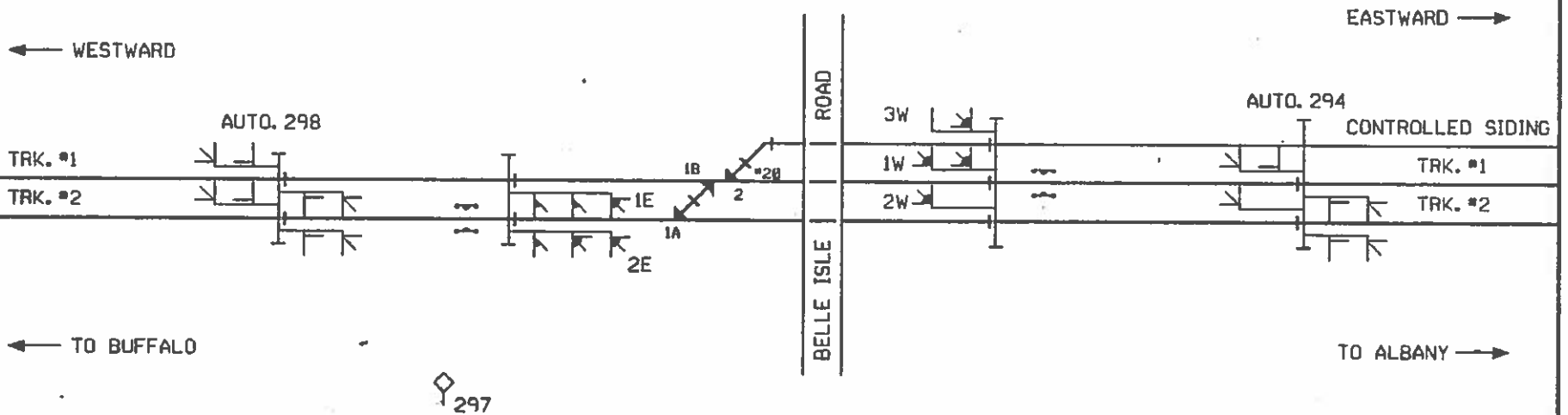

NOTES: CONTROLLED FROM BUFFALO
 SYNCRO - SCAN
 E.B. APP. - AUTO. 298 TRKS. 1 & 2
 W.B. APP. - AUTO. 294 TRKS. 1 & 2
 SW. 1A - MOD. 5A W/COFFIN
 SW. 1B - MOD. 5C
 SW. 2 - MOD. 5G

BUFFALO DIVISION NORTHEASTERN REGION	CONRAIL C. & S. DEPT.	PHILADELPHIA, PA.
C.P. 296 BELLE ISLE, NEW YORK		
REV. NO.	DATE: 1-1-84	SH. 3
SCALE: NONE		

C.P. 300

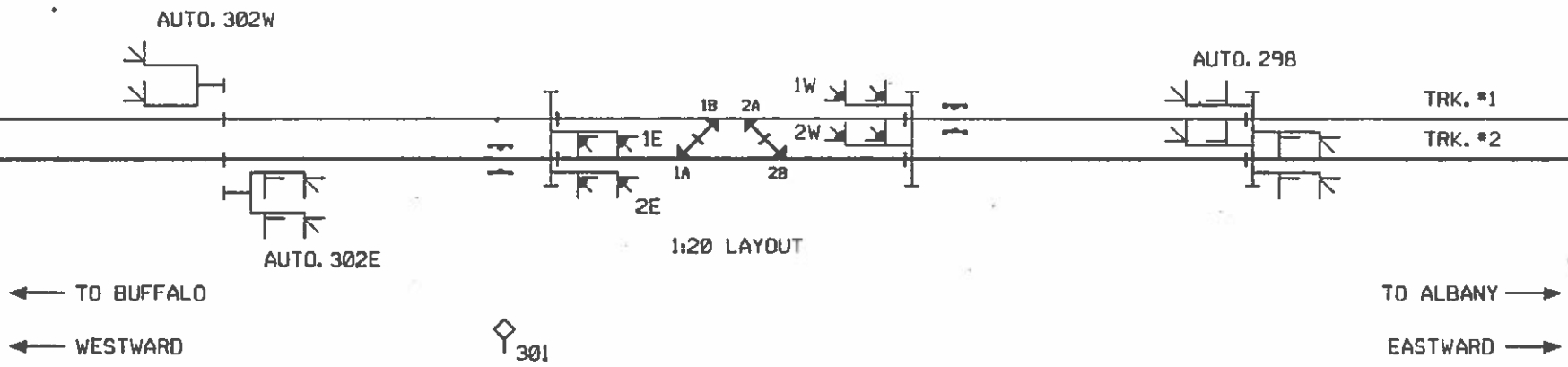

NOTES: CONTROLLED FROM BUFFALO
 SYNCRO - SCAN
 W.B. APP. - AUTO. 298 TRKS. 1 & 2
 E.B. APP. - AUTO. 302 TRKS. 1 & 2
 ALL SW. MACHS. - MOD. 5C

BUFFALO DIVISION NORTHEASTERN REGION	CONRAIL E. & S. DEPT.	PHILADELPHIA, PA.
<h2 style="margin: 0;">C.P. 300</h2> <p style="margin: 0;">EAST OF WARNER, NEW YORK</p>		
REV. NO.	DATE: 1-1-84	SH. 4
SCALE: NONE		

C.P. 306

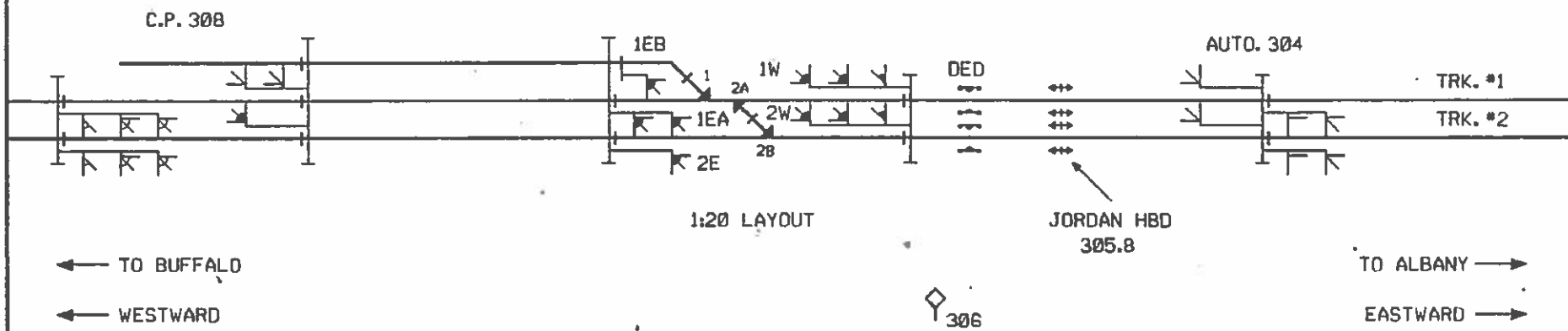

NOTES: CONTROLLED FROM BUFFALO
 SYNCRO - SCAN
 W.B. APP. - AUTO 304
 E.B. APP. - C.P. 6
 ALL SW. MACHS. - MOD. 5C

BUFFALO DIVISION NORTHEASTERN REGION	CONRAIL C. & S. DEPT.	PHILADELPHIA, PA.
C.P. 306 WEST OF WARNER, NEW YORK		
REV. NO.	DATE: 1-1-84	SH. 5
SCALE: NONE		

C.P. 308
 CONTROLLED FROM BUFFALO
 SYNCRO - SCAN

AUTO. 310
 E.B. APP.

H'WAY 3089
 COLD SPRING

C.P. 306
 W.B. APP.

← TO BUFFALO
 ← WESTWARD

TO ALBANY →
 EASTWARD →

309

1:20 LAYOUT

SW. 1A - 5G
 SW. 1B - 55
 SW. 2 - 55

BUFFALO DIVISION NORTHEASTERN REGION	CONRAIL C. & S. DEPT.	PHILADELPHIA, PA.
---	--------------------------	-------------------

C.P. 308
 WEST OF JORDAN, NEW YORK

REV. NO.	DATE: 1-1-84	SH. 6
----------	--------------	-------

SCALE: NONE

C.P. 313
 CONTROLLED FROM BUFFALO
 SYNCRO - SCAN

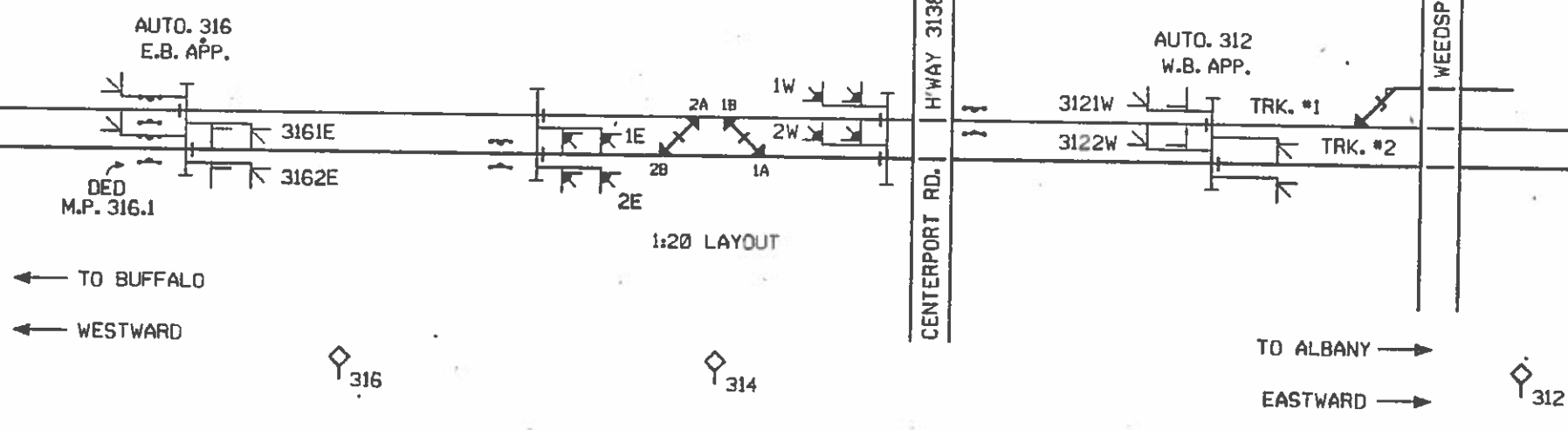

← TO BUFFALO
 ← WESTWARD

TO ALBANY →
 EASTWARD →

- SW. 1A - 55
- SW. 1B - 5C
- SW. 2A - 5A OUTBOARD BRAKE
- SW. 2B - 5A OUTBOARD BRAKE

BUFFALO DIVISION NORTHEASTERN REGION	CONRAIL C. & S. DEPT.	PHILADELPHIA, PA.
C.P. 313 NORTH PORT BYRON, NEW YORK		
REV. NO.	DATE: 1-1-84	SH. 7
SCALE: NONE		

C.P. 320
 CONTROLLED FROM BUFFALO
 SYNCRO - SCAN

C.P. 323
 E.B. APP.

AUTO. 318
 W.B. APP.

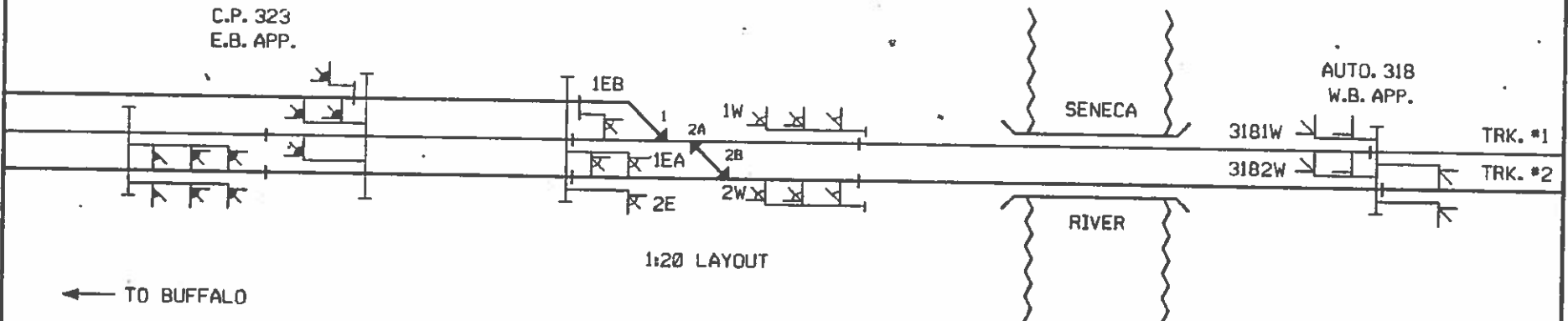

1:20 LAYOUT

← TO BUFFALO

← WESTWARD

TO ALBANY →

EASTWARD →

SW. 1 - 5C
 SW. 2A - 5C
 SW. 2B - 5G

BUFFALO DIVISION NORTHEASTERN REGION	CONRAIL C. & S. DEPT.	PHILADELPHIA, PA.
C.P. 320 SENECA RIVER, NEW YORK		
REV. NO.	DATE: 1-1-84	SH. 8
SCALE: NONE		

C.P. 323

CONTROLLED FROM BUFFALO
SYNCRO - SCAN

← TO BUFFALO
← WESTWARD

AUTO. 324
E.B. APP.

C.P. 320
W.B. APP.

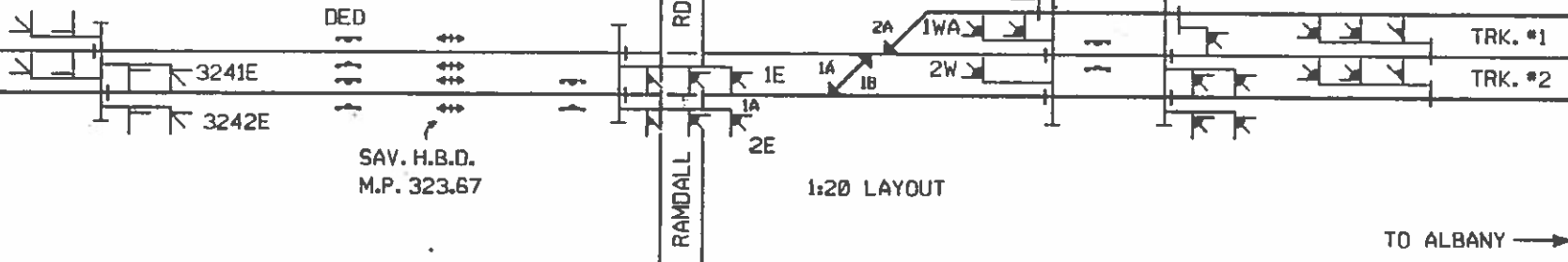

◇ 325

◇ 323

TO ALBANY →
EASTWARD →

SW. 1A - 5C
SW. 1B - 5C
SW. 2A - 5C

BUFFALO DIVISION NORTHEASTERN REGION	CONRAIL C. & S. DEPT.	PHILADELPHIA, PA.
<p>C.P. 323 WEST OF SAVANNAH, NEW YORK</p>		
REV. NO.	DATE: 1-1-84	SH. 9
SCALE: NONE		

C.P. 326
 CONTROLLED FROM BUFFALO
 SYNCRO - SCAN

WESTWARD
 TO BUFFALO

EASTWARD
 TO ALBANY

C.P. 329
 E.B. APP.

AUTO. 324
 W.B. APP.

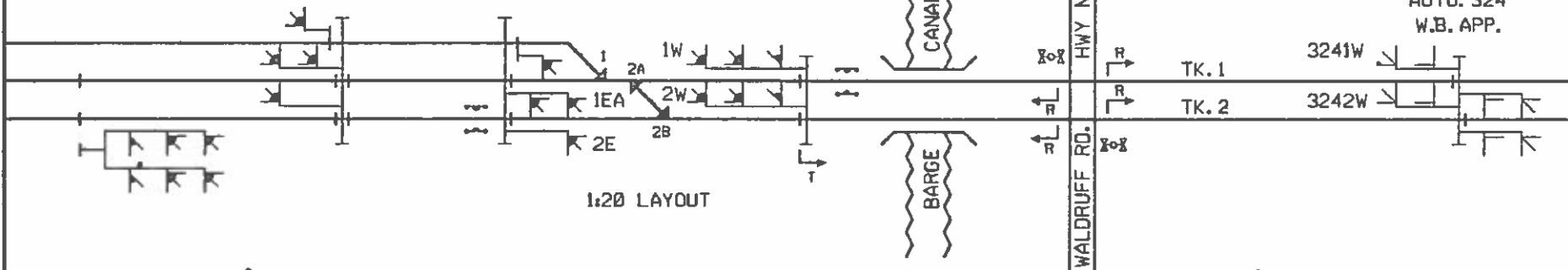

1:20 LAYOUT

327

325

ALL SWS. SPIKED
 OUT OF SERVICE

- SW. 1 - 5G
- SW. 2A - 5G
- SW. 2B - 5G

BUFFALO DIVISION	CONRAIL C. & S. DEPT.	PHILADELPHIA, PA.
C.P. 326 EAST OF CLYDE, NEW YORK		
REV. NO.	DATE: 1-1-84	SH. 10
SCALE: NONE		

C.P. 329
 CONTROLLED FROM BUFFALO
 SYNCRO - SCAN

← TO BUFFALO
 ← WESTWARD

AUTO. 331
 E.B. APP.

C.P. 326
 W.B. APP.

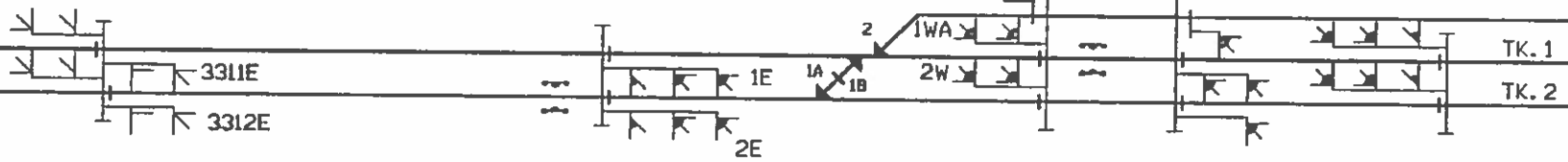

1:20 LAYOUT

TO ALBANY →
 EASTWARD →

◇ 331

◇ 329

ALL SWS. SPIKED
 OUT OF SERVICE

- SW. 1A - 5G
- SW. 1B - 5G
- SW. 2 - 5C

BUFFALO DIVISION NORTHEASTERN REGION	CONRAIL C. O. & N. Y.	PHILADELPHIA, PA.
---	--------------------------	-------------------

C.P. 329
 WEST OF CLYDE, NEW YORK

REV. NO.	DATE: 1-1-84	SH. 11
----------	--------------	--------

SCALE: NONE

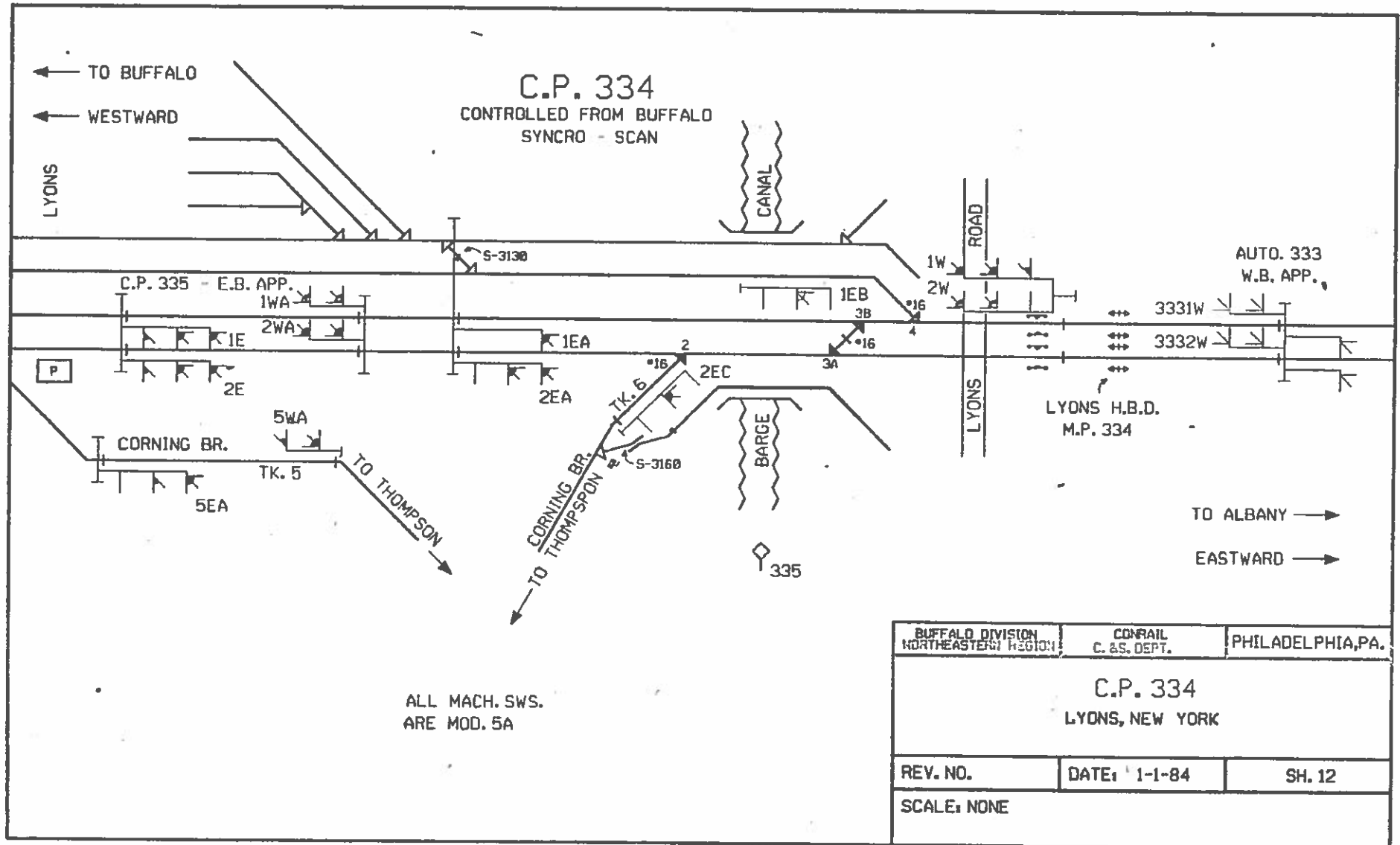

ALL MACH. SWS.
ARE MOD. 5A

BUFFALO DIVISION NORTHEASTERN REGION	CONRAIL C. & S. DEPT.	PHILADELPHIA, PA.
C.P. 334 LYONS, NEW YORK		
REV. NO.	DATE: 1-1-84	SH. 12
SCALE: NONE		

C.P. 335
 CONTROLLED FROM BUFFALO
 SYNCRO - SCAN

← TO BUFFALO
 ← WESTWARD

AUTO. 338
 E.B. APP.

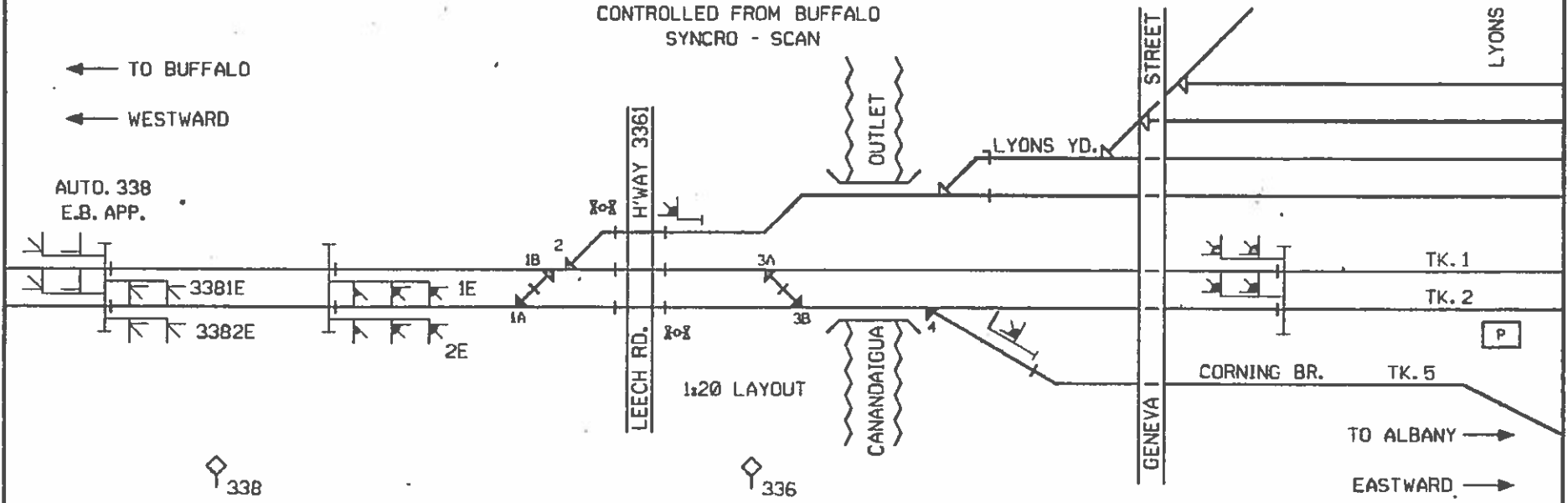

ALL SW. MACHINES
 ARE MODEL 5A.

BUFFALO DIVISION NORTHEASTERN REGION	CONRAIL C. & S. DEPT.	PHILADELPHIA, PA.
C.P. 335 LYONS, NEW YORK		
REV. NO.	DATE: 1-1-84	SH. 13
SCALE: NONE		

C.P. 340
 CONTROLLED FROM BUFFALO
 SYNCRO - SCAN

← TO BUFFALO

← WESTWARD

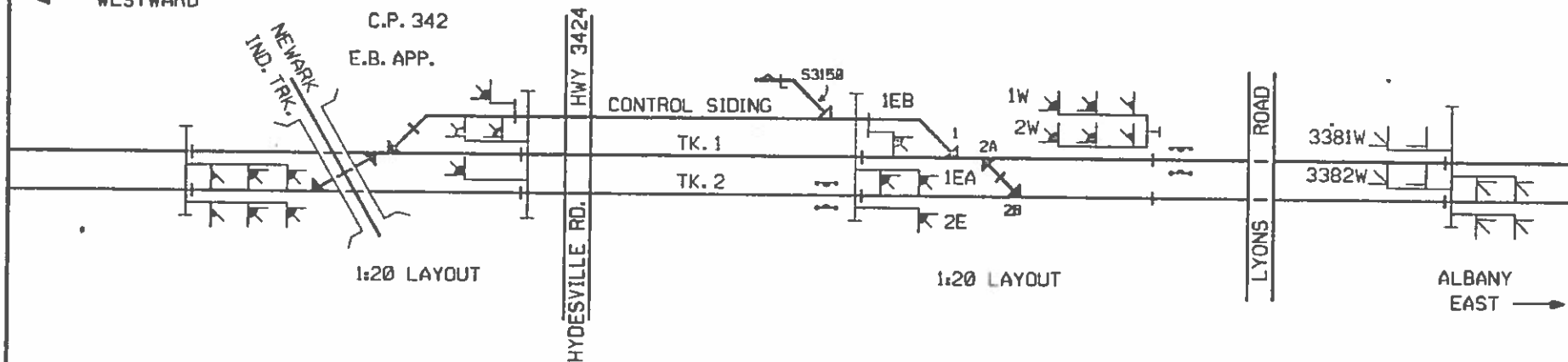

C.P. 342
 E.B. APP.

HWY 3424
 HYDESVILLE RD.

LYONS ROAD

1:20 LAYOUT

1:20 LAYOUT

340

338

SW.1A - 5C
 ALL OTHER SWITCHES SPIKED
 OUT OF SERVICE
 SW.2A & 2B - 5G

BUFFALO DIVISION NORTHEAST DIVISION	CONRAIL C. & S. DEPT.	PHILADELPHIA, PA.
C.P. 340 EAST OF NEWARK, NEW YORK		
REV. NO.	DATE: 1-1-84	SH. 14
SCALE: NONE		

C.P. 342

CONTROLLED FROM BUFFALO
SYNCHRO-SCAN

C.P. 340
W.B. APP.

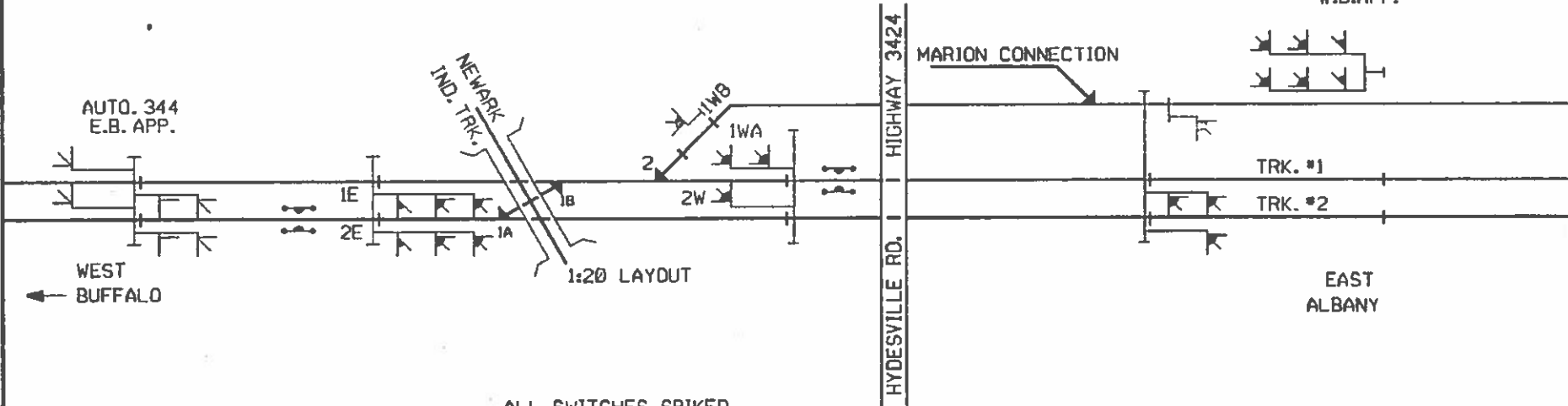

ALL SWITCHES SPIKED
OUT OF SERVICE.

- SW. 1A - 5C
- SW. 1B - 5C
- SW. 2 - 5C

BUFFALO DIVISION NORTHEASTERN REGION	CONRAIL C. & S. DEPT.	PHILADELPHIA PA.
---	--------------------------	------------------

C.P. 342
WEST OF NEWARK, N.Y.

REV. NO.	DATE: 1-1-84	SH. 15
----------	--------------	--------

SCALE: NONE

C.P. 349

CONTROLLED FROM BUFFALO
SYNCRIO-SCAN

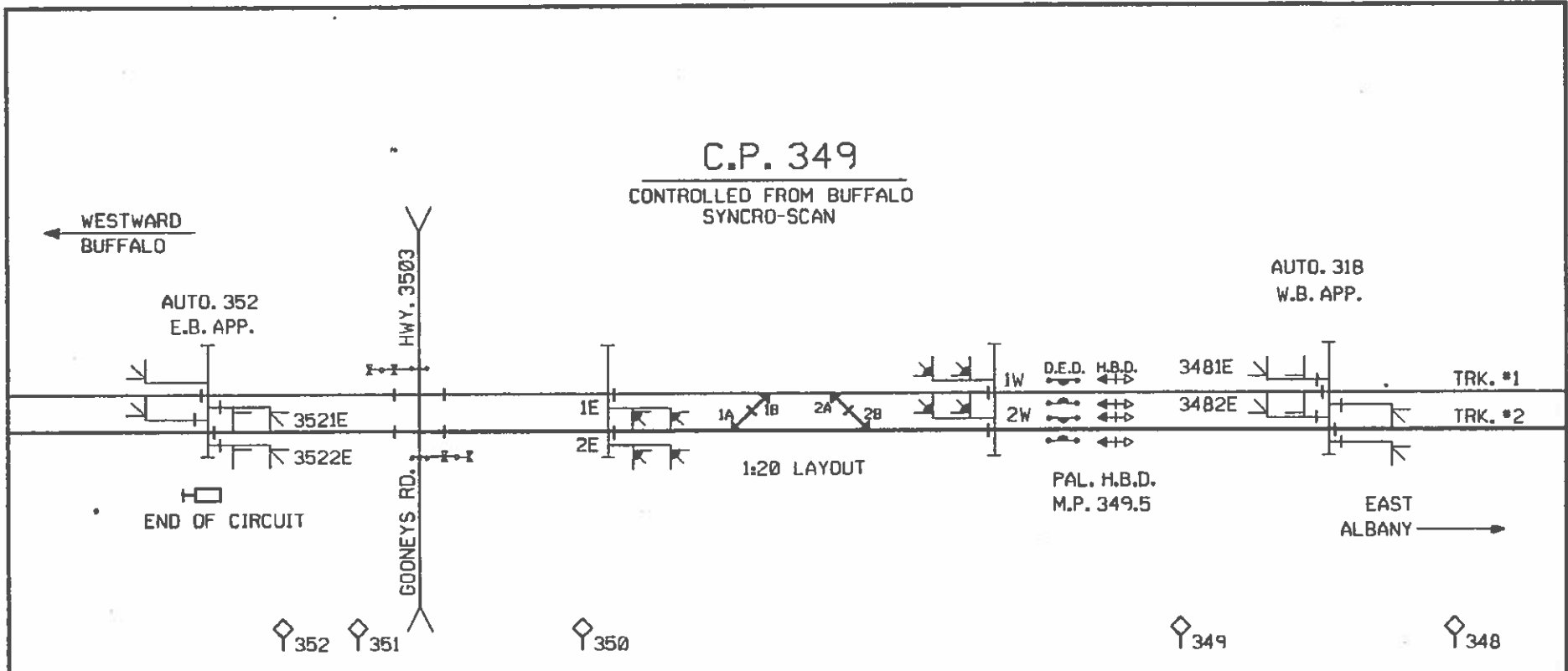

- SW. 1A - 5C
- SW. 1B - 5C
- SW. 2A - 5C
- SW. 2B - 5C

BUFFALO DIVISION NORTHEASTERN REGION	CONRAIL C. S. DEPT.	PHILADELPHIA, PA.
<p>C.P. 349 WEST OF PALMYRA, N.Y.</p>		
REV. NO.	DATE: 1-1-82	SH. 16
SCALE: NONE		

"C.P. 356"

E. OF WAYNEPORT, N.Y.
CONTROLLED FROM BUFFALO
SYNCHRO-SCAN

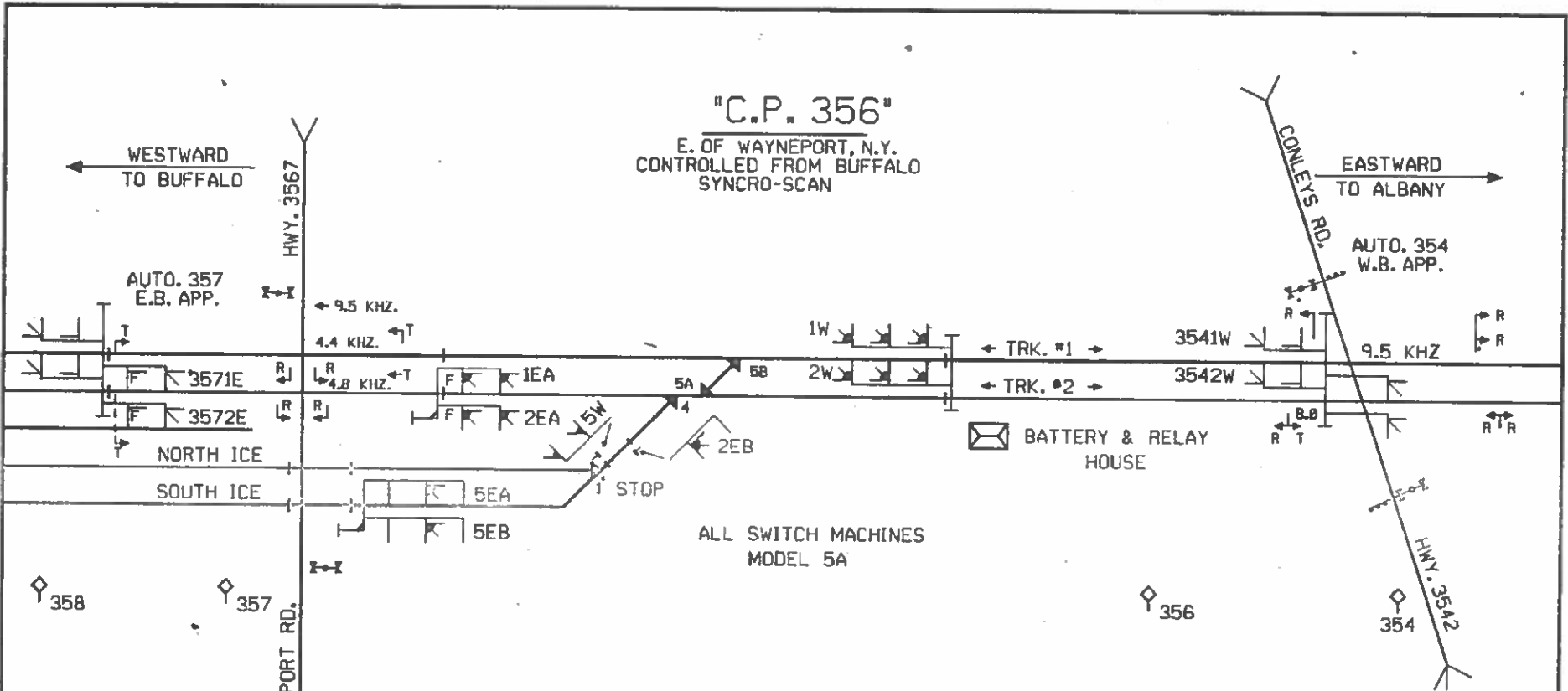

CONRAIL BUFFALO DIVISION	CONRAIL C. & S. DEPT.	PHILADELPHIA, PA.
C.P. 356 E. OF WAYNEPORT, N.Y.		
REV. NO.	DATE: 1-1-84	SH. 17
SCALE: NONE		

"C.P. 359"

W. OF WAYNEPORT, N.Y.
CONTROLLED FROM BUFFALO
SYNCR0-SCAN

WESTWARD
TO BUFFALO

EASTWARD
TO ALBANY

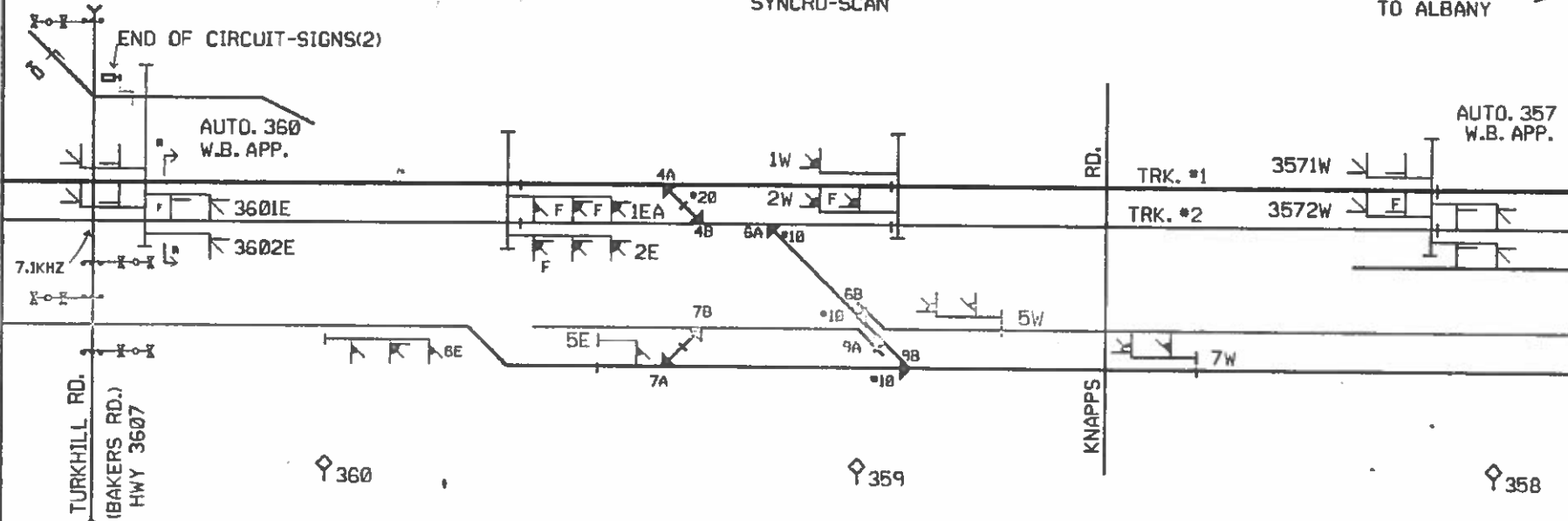

- S.W. 4A & 4B - 5C
- S.W. 6A & 6B - 5A WITH COFFIN
- S.W. 7A & 7B -
- S.W. 9B -
- S.W. 9A - 5H

CONRAIL BUFFALO DIVISION	CONRAIL C. & S. DEPT.	PHILADELPHIA, PA.
C.P. 359 W. OF WAYNEPORT, N.Y.		
REV. NO.	DATE: 1-1-84	SH. 18
SCALE: NONE		

"C.P. 362"

E. OF EAST ROCHESTER, N.Y.
CONTROLLED FROM BUFFALO
SYNCHRO-SCAN

WESTWARD
TO BUFFALO

EASTWARD
TO ALBANY

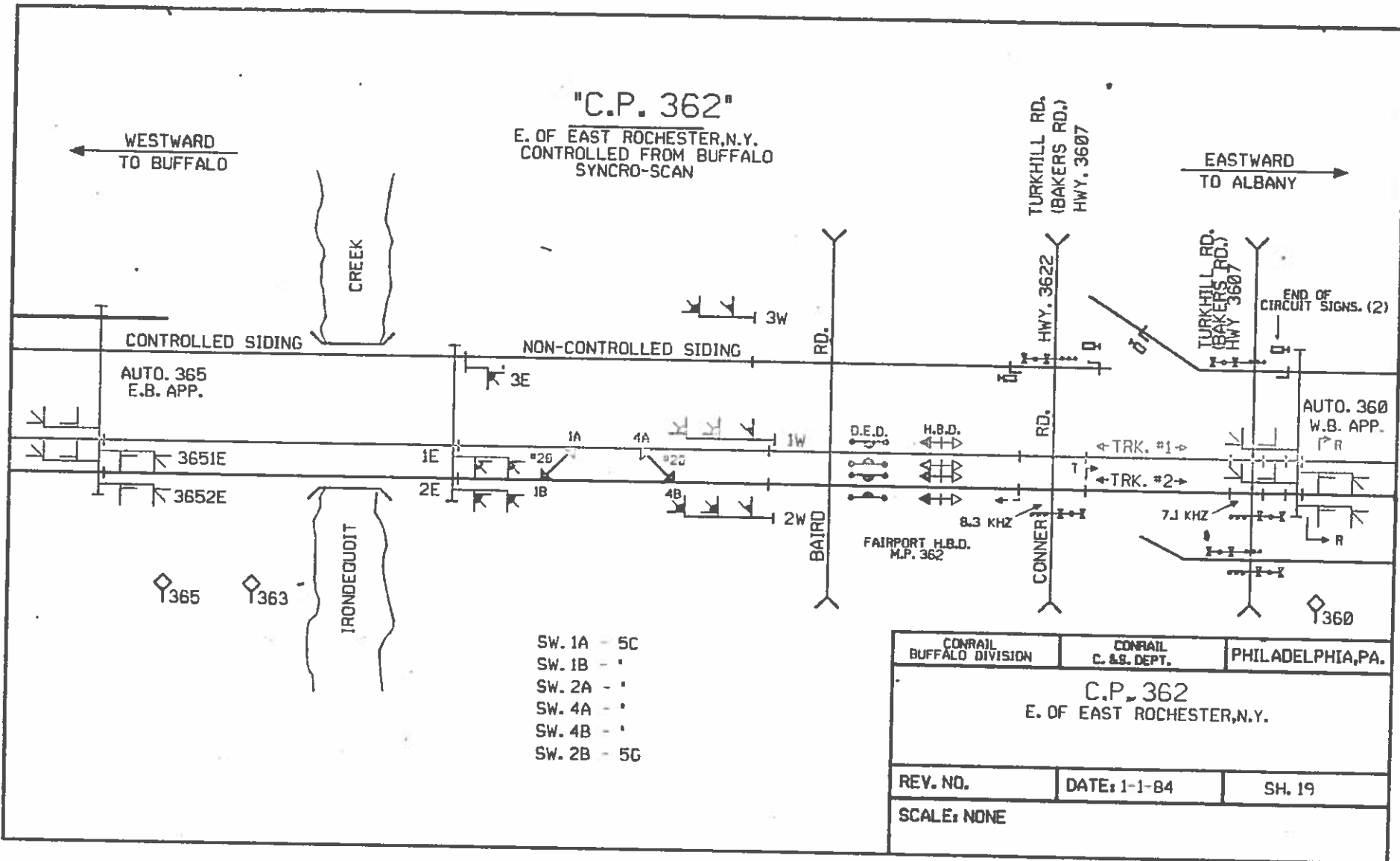

- SW. 1A - 5C
- SW. 1B - "
- SW. 2A - "
- SW. 4A - "
- SW. 4B - "
- SW. 2B - 5G

CONRAIL BUFFALO DIVISION	CONRAIL C. & S. DEPT.	PHILADELPHIA, PA.
C.P. 362 E. OF EAST ROCHESTER, N.Y.		
REV. NO.	DATE: 1-1-84	SH. 19
SCALE: NONE		

← TO BUFFALO
← WESTWARD

C.P. 367
BRIGHTON
T.C.S. SYNCRO-SCAN
BUFFALO, N.Y.

→ EASTWARD
→ TO ALBANY

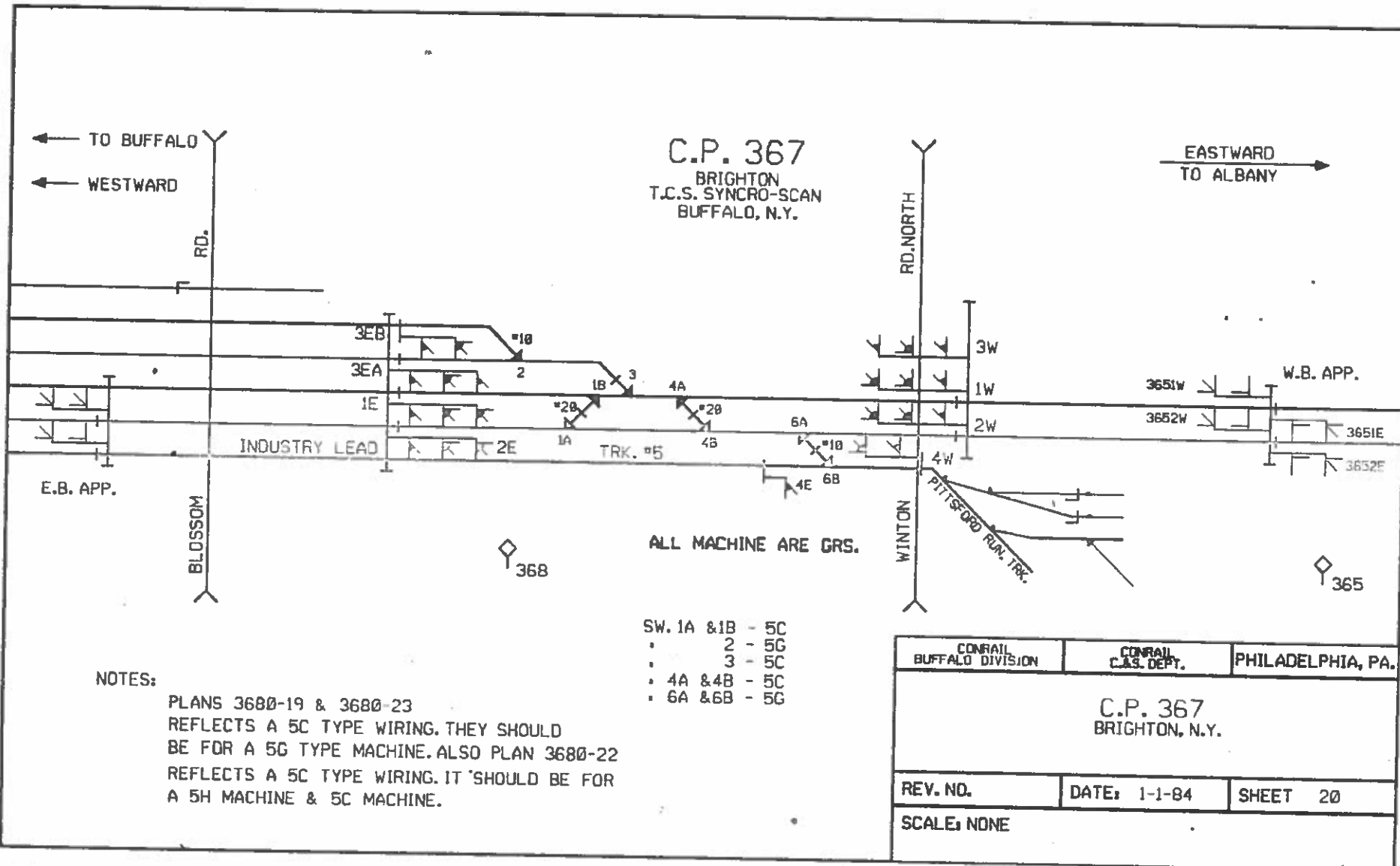

NOTES:

PLANS 3680-19 & 3680-23
REFLECTS A 5C TYPE WIRING. THEY SHOULD
BE FOR A 5G TYPE MACHINE. ALSO PLAN 3680-22
REFLECTS A 5C TYPE WIRING. IT SHOULD BE FOR
A 5H MACHINE & 5C MACHINE.

- SW. 1A & 1B - 5C
- 2 - 5G
- 3 - 5C
- 4A & 4B - 5C
- 6A & 6B - 5G

CONRAIL BUFFALO DIVISION	CONRAIL C.A.S. DEPT.	PHILADELPHIA, PA.
C.P. 367 BRIGHTON, N.Y.		
REV. NO.	DATE: 1-1-84	SHEET 20
SCALE: NONE		

SIREN DOES'NT WORK &
CALL LIGHT DOES'NT REVOLVE.

C.P. 369
EAST OF ROCHESTER
T.C.S. "SYNCR SCAN"
BUFFALO, N.Y.

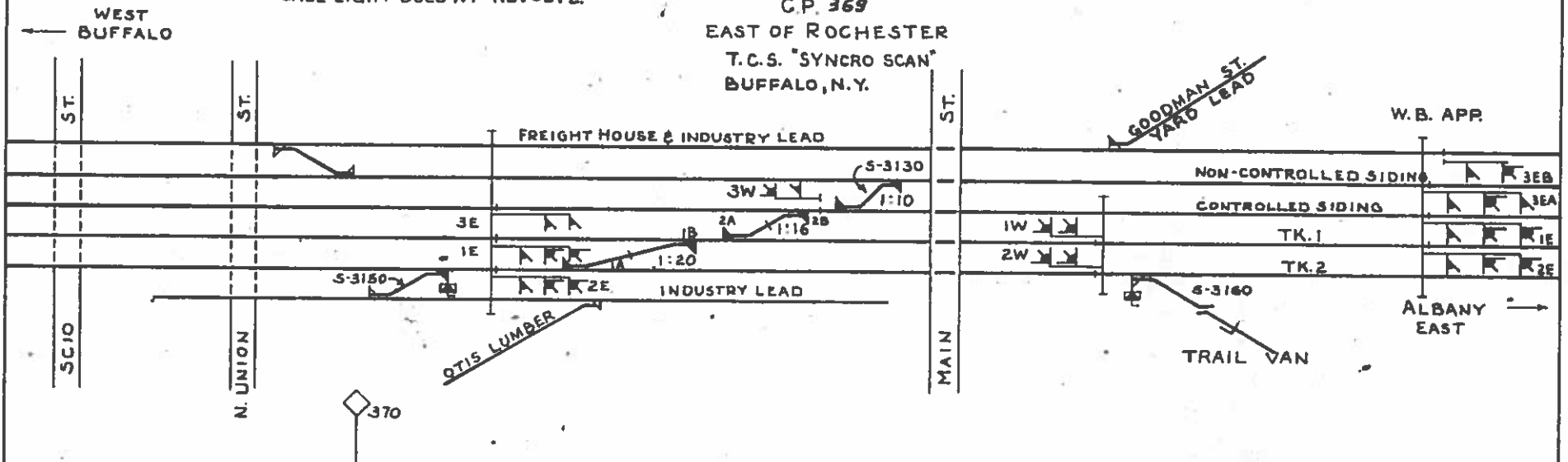

NOTE: PLAN 4800-3700 SH.15
DOES NOT REFLECT A 5H MACHINE
FOR SW. 2A.

1A - 5G
1B - 5G
2A - 5H
2B - 5G
ALL MACHINES
GRS

CONRAIL BUFFALO DIV. N.E. REGION	C. & S. DEPT.	PHILADELPHIA, PA.
C.P. 369 EAST OF ROCHESTER, N.Y.		
REV. NO.	1-1-84	PG. 21
SCALE: NONE		

C.P. 371
 KENT ST. - ROCHESTER
 T.C.S. "SYNCRON SCAN"
 BUFFALO, N.Y.

← NEXT SIGNAL AT
 CP 373

KENT ST. YARD LEAD
 RT 4EB

NEXT SIGNAL AT →
 CP 369

← WEST
 BUFFALO

SW.1 - SC
 ALL MACHINES
 G.R.S.

PLYMOUTH

STATE

MILL

EAST ALBANY →

NOTE: CKT. WORK TO
 BE DONE HERE.

CONRAIL BUFFALO DIV.	COMM. SIGNALS	PHILADELPHIA, PA.
N.E. REGION		
C.P. 371 KENT STREET ROCHESTER, N.Y.		
REV. NO.	1-1-84	PG 22
SCALE: NONE		
NEW PLAN DRAWN -		VAB

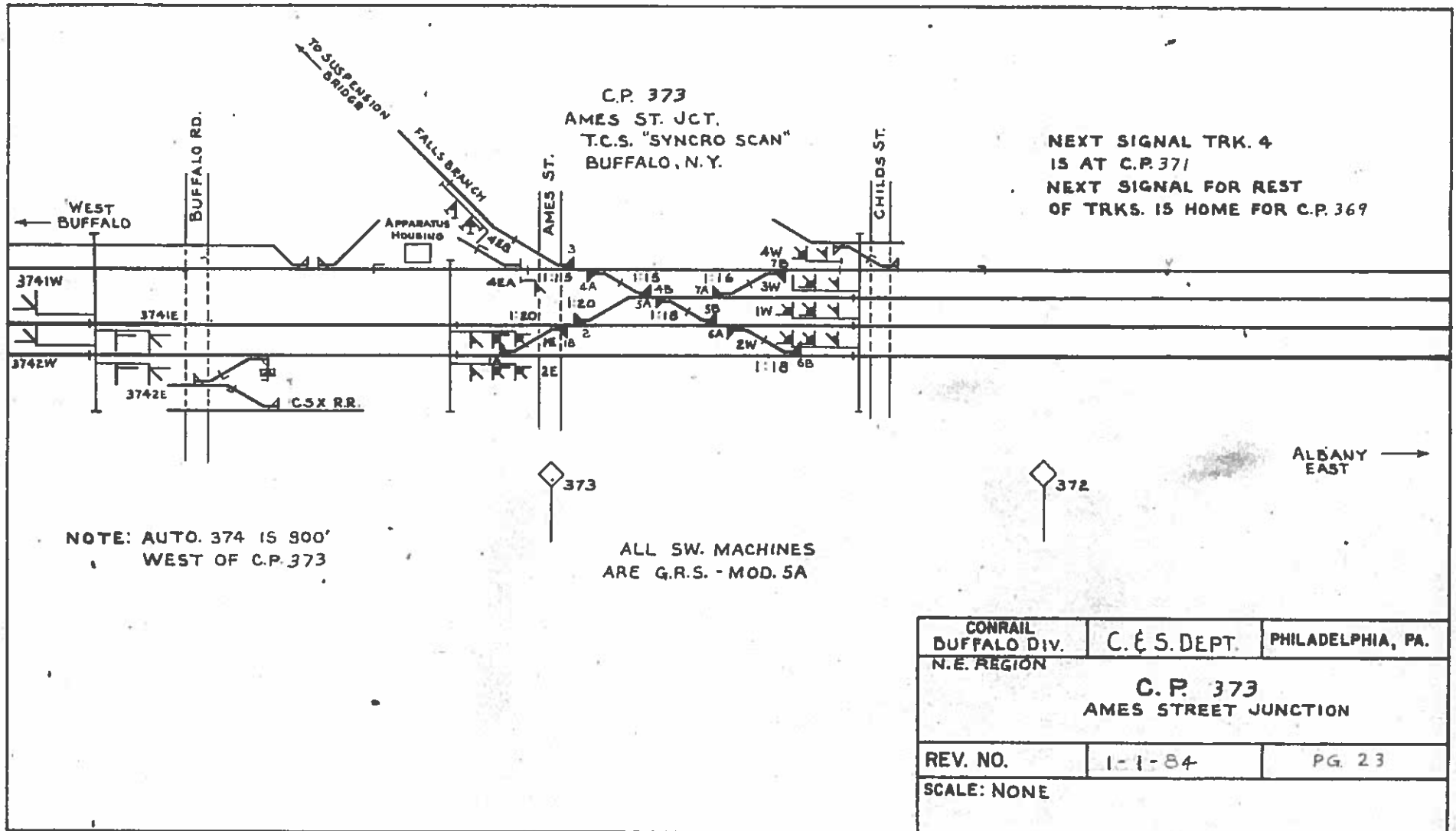

C.P. 373
 AMES ST. JCT.
 T.C.S. "SYNCR SCAN"
 BUFFALO, N. Y.

NEXT SIGNAL TRK. 4
 IS AT C.P. 371
 NEXT SIGNAL FOR REST
 OF TRKS. IS HOME FOR C.P. 369

NOTE: AUTO. 374 IS 900'
 WEST OF C.P. 373

ALL SW. MACHINES
 ARE G.R.S. - MOD. 5A

CONRAIL BUFFALO DIV. N.E. REGION	C. & S. DEPT.	PHILADELPHIA, PA.
C. P. 373 AMES STREET JUNCTION		
REV. NO.	1-1-84	PG. 23
SCALE: NONE		

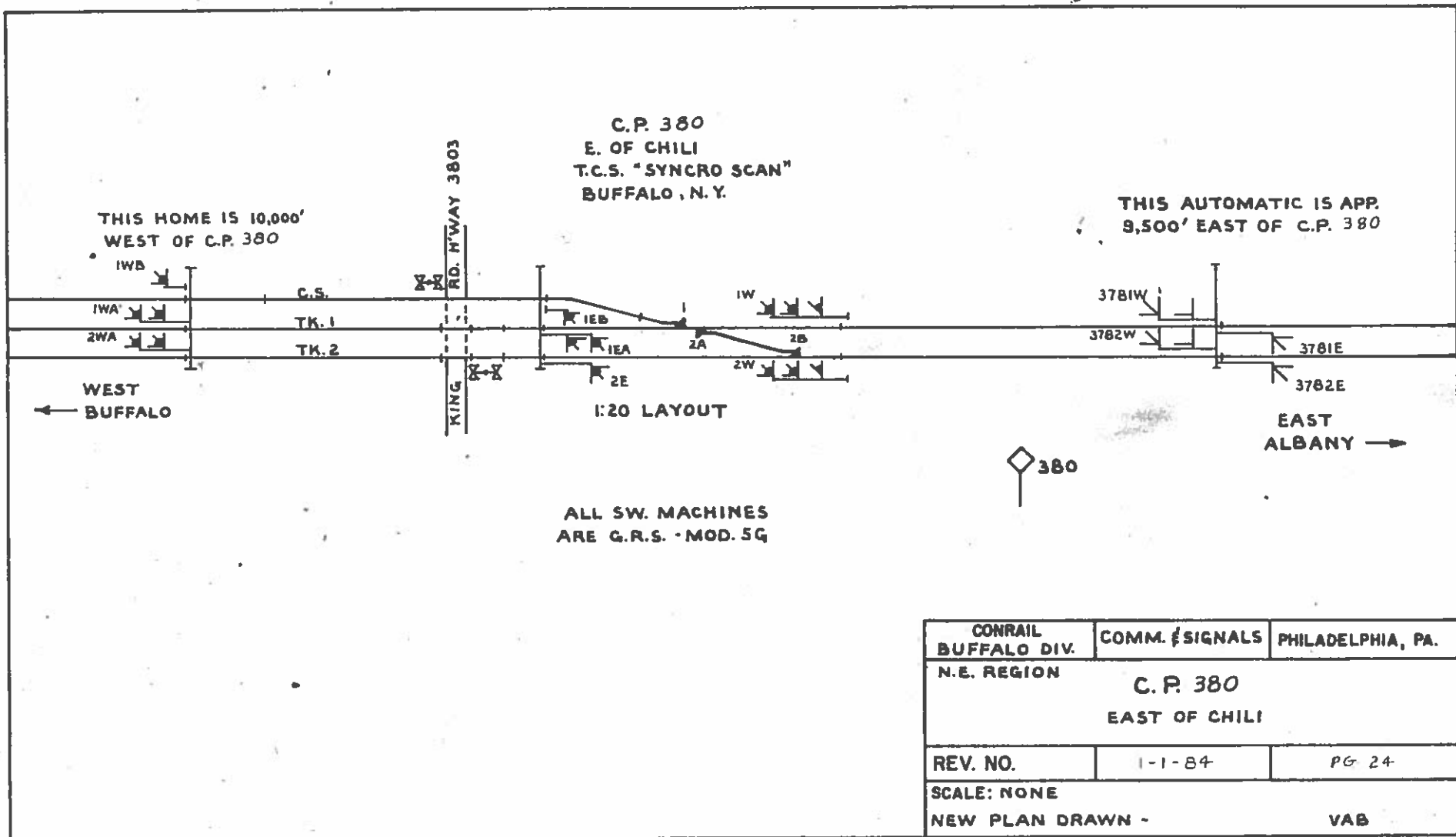

CONRAIL BUFFALO DIV.	COMM. & SIGNALS	PHILADELPHIA, PA.
N.E. REGION		
C. P. 380 EAST OF CHILI		
REV. NO.	1-1-84	PG 24
SCALE: NONE		
NEW PLAN DRAWN -		VAB

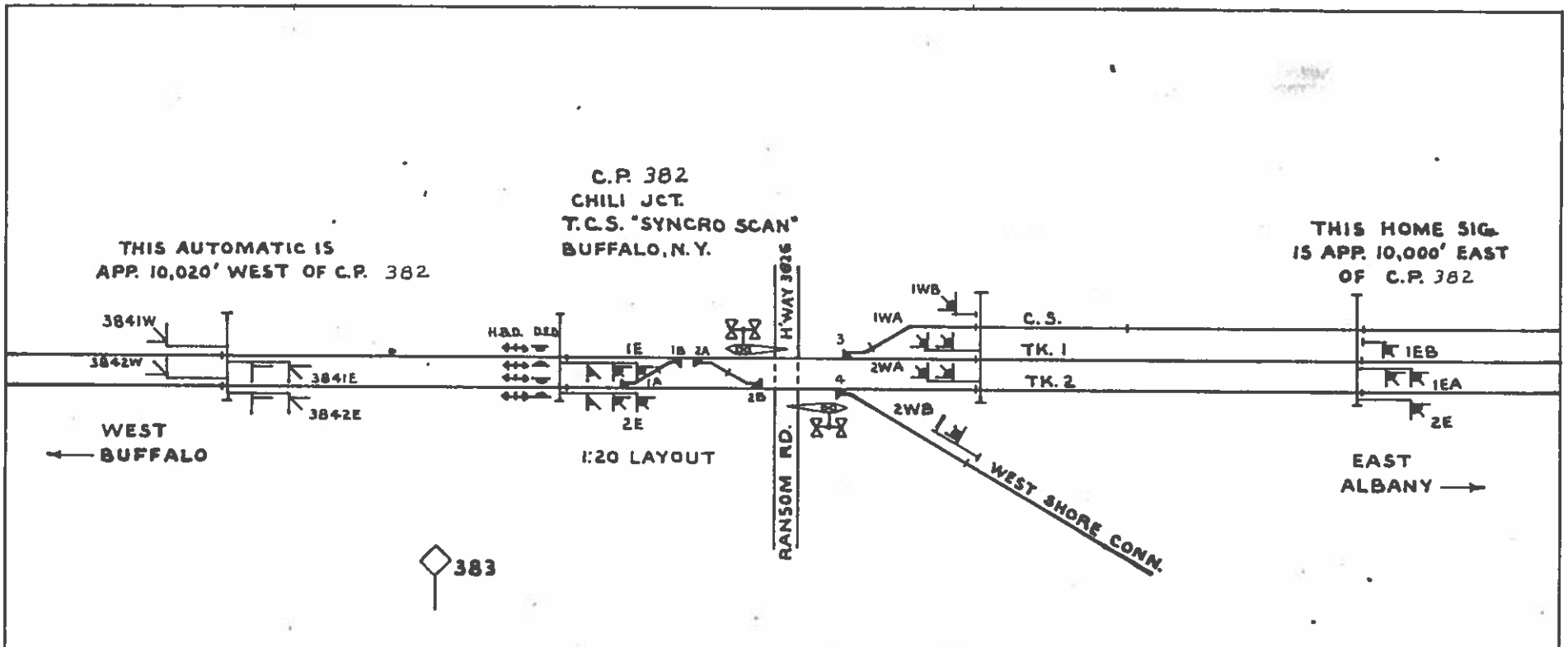

*1A/B - 5C
 *2A/B - 5C
 * 3 - 5C
 * 4 - 5G
 ALL SW. MACHINES
 G.R.S.

CONRAIL BUFFALO DIV.	COMM./SIGNALS	PHILADELPHIA, PA.
N.E. REGION		
C.P. 382 CHILI JUNCTION		
REV. NO.	1-1-84	PG 25
SCALE: NONE		
NEW PLAN DRAWN -		VAB

THIS HOME IS APP.
300' WEST OF C.P. 388

C.P. 388
BERGEN, N.Y.
T.C.S. "SYNCR SCAN"
BUFFALO, N.Y.

THIS AUTOMATIC IS APP.
5,200' EAST OF C.P. 388

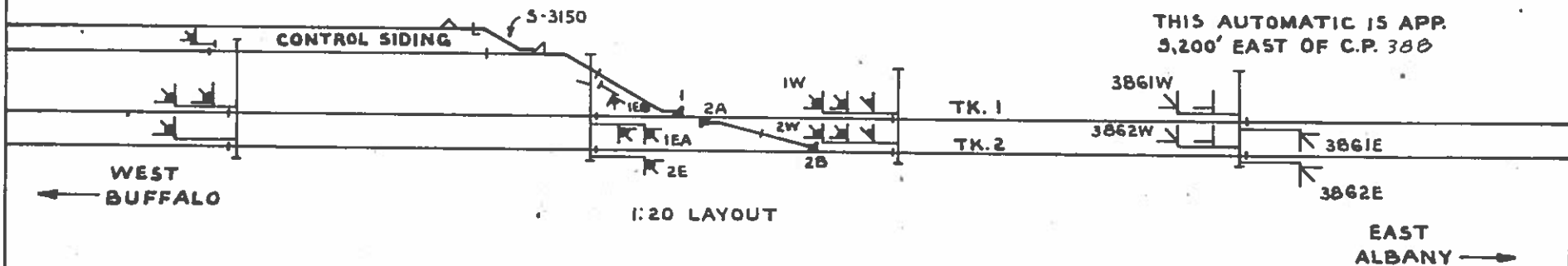

1:20 LAYOUT

* 1 - 5C
* 2A - 5G
* 2B - 5G
ALL SW. MACHINES
G.R.S.



CONRAIL BUFFALO DIV.	COMM. SIGNALS	PHILADELPHIA, PA.
N.E. REGION		
C.P. 388 BERGEN, N.Y.		
REV. NO.	1-1-84	PG 26
SCALE: NONE		
NEW PLAN DRAWN		VAB

C.P. 390
 W. OF BERGEN
 T.C.S. "SYNCRON SCAN"
 BUFFALO, N.Y.

THIS HOME SIGNAL
 IS APP. 900' EAST OF C.P. 390

THIS AUTOMATIC IS
 7,700' WEST
 OF C.P. 390

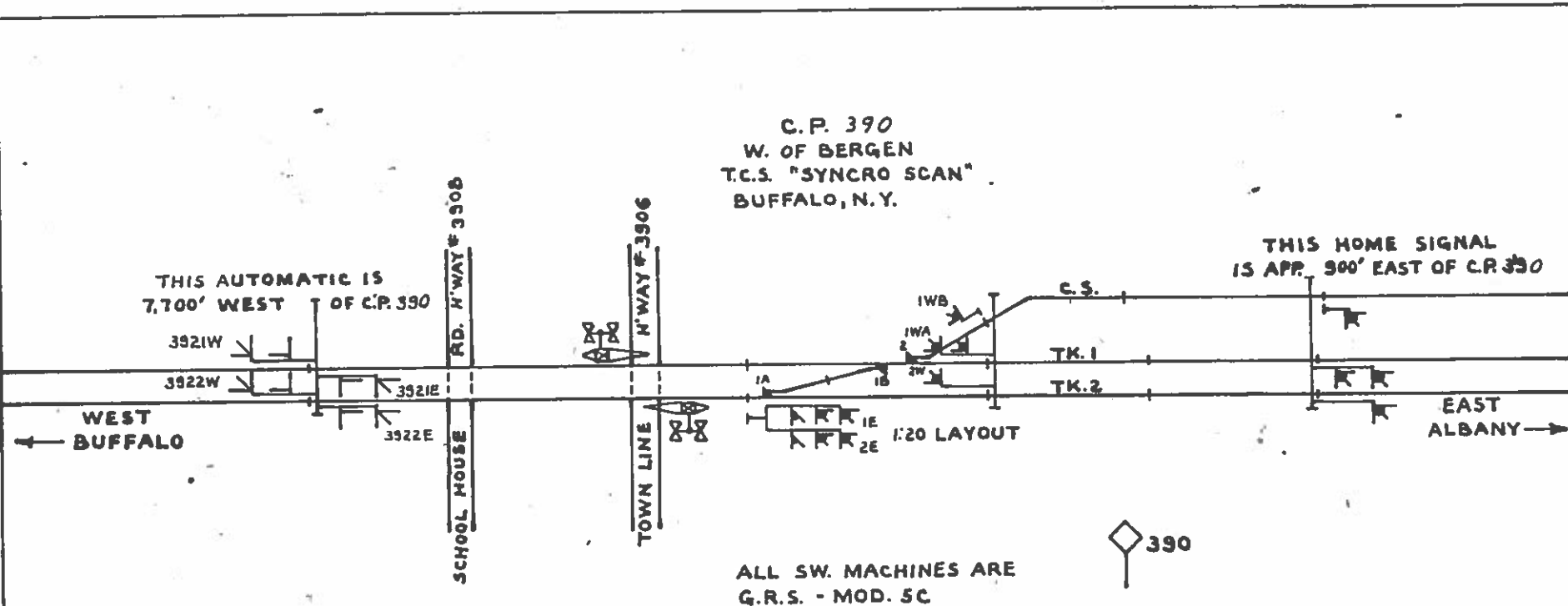

ALL SW. MACHINES ARE
 G.R.S. - MOD. 5C

CONRAIL BUFFALO DIV.	COMM. SIGNALS	PHILADELPHIA, PA.
N.E. REGION		
C.P. 390 W. OF BERGEN, N.Y.		
REV. NO.	1-1-84	PG 27
SCALE: NONE		
NEW PLAN DRAWN -		VAB

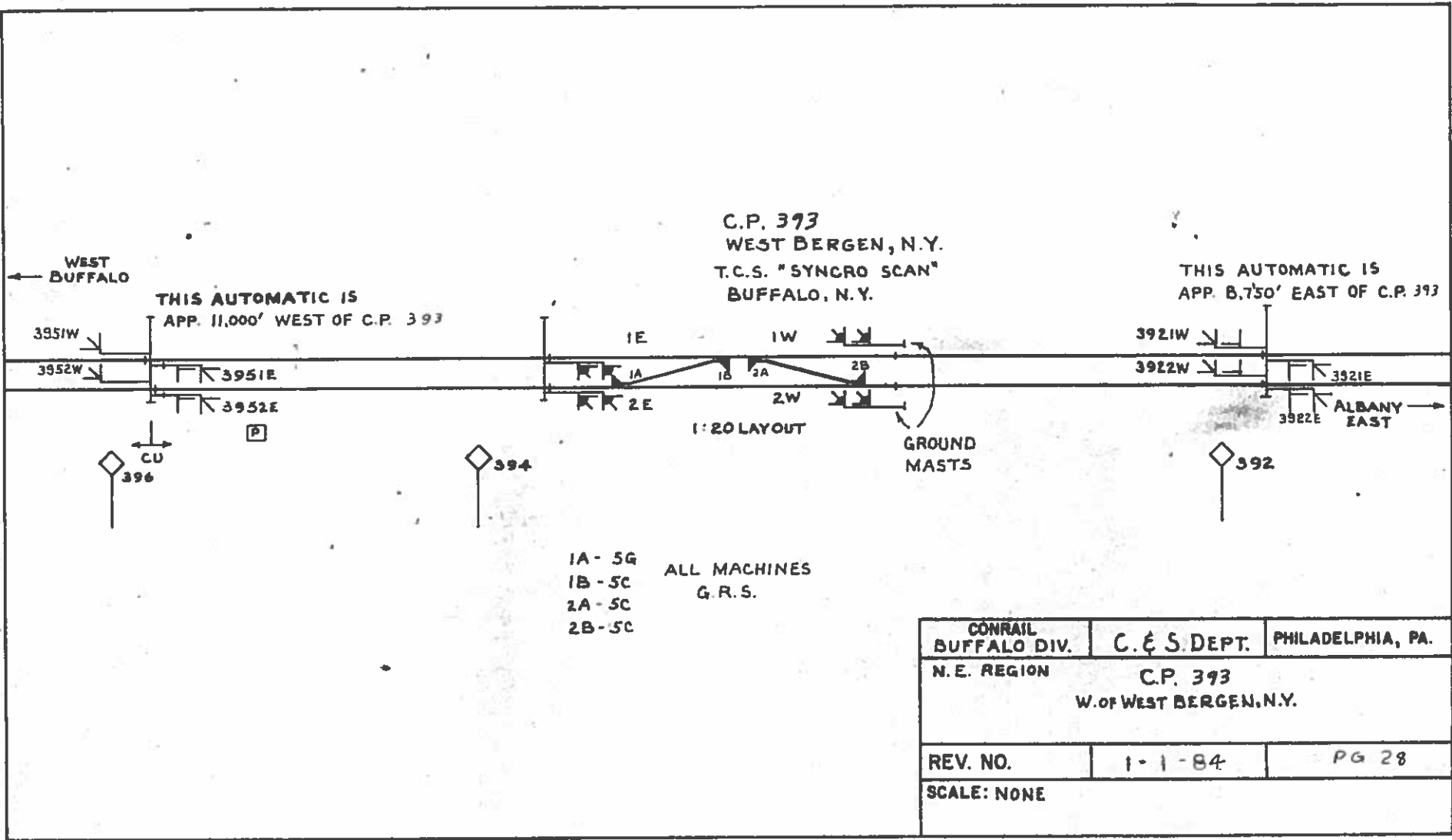

CONRAIL BUFFALO DIV.	C. & S. DEPT.	PHILADELPHIA, PA.
N. E. REGION		C.P. 393 W. OF WEST BERGEN, N.Y.
REV. NO.	1-1-84	PG 28
SCALE: NONE		

C.P. 402
E. OF BATAVIA

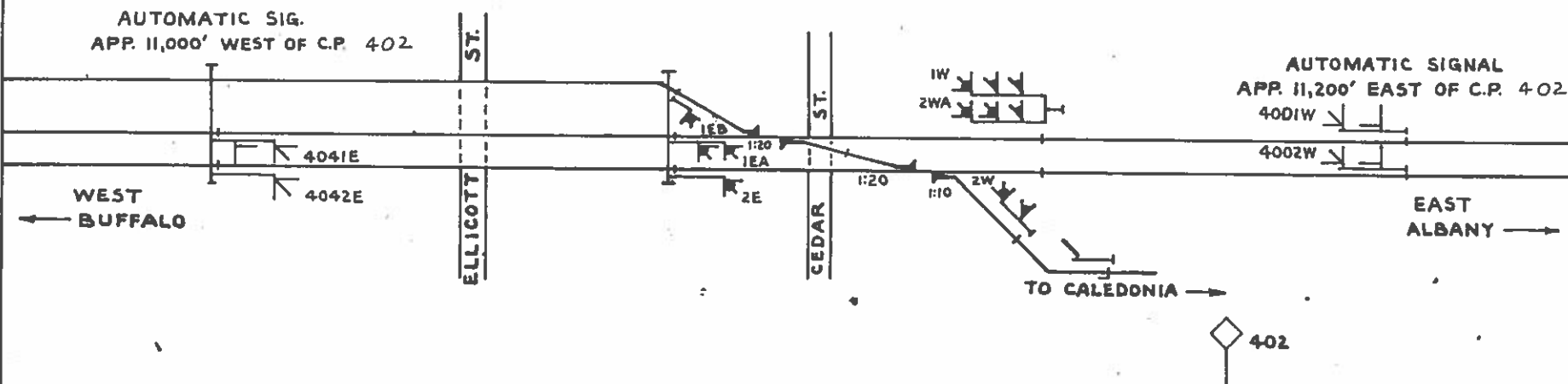

CONRAIL
BUFFALO DIV. COMM. SIGNALS PHILADELPHIA, PA.
N.E. REGION

C.P. 402
E. OF BATAVIA, N.Y.

REV. NO. 1-1-84 PG. 29

SCALE: NONE
NEW PLAN DRAWN - VAB

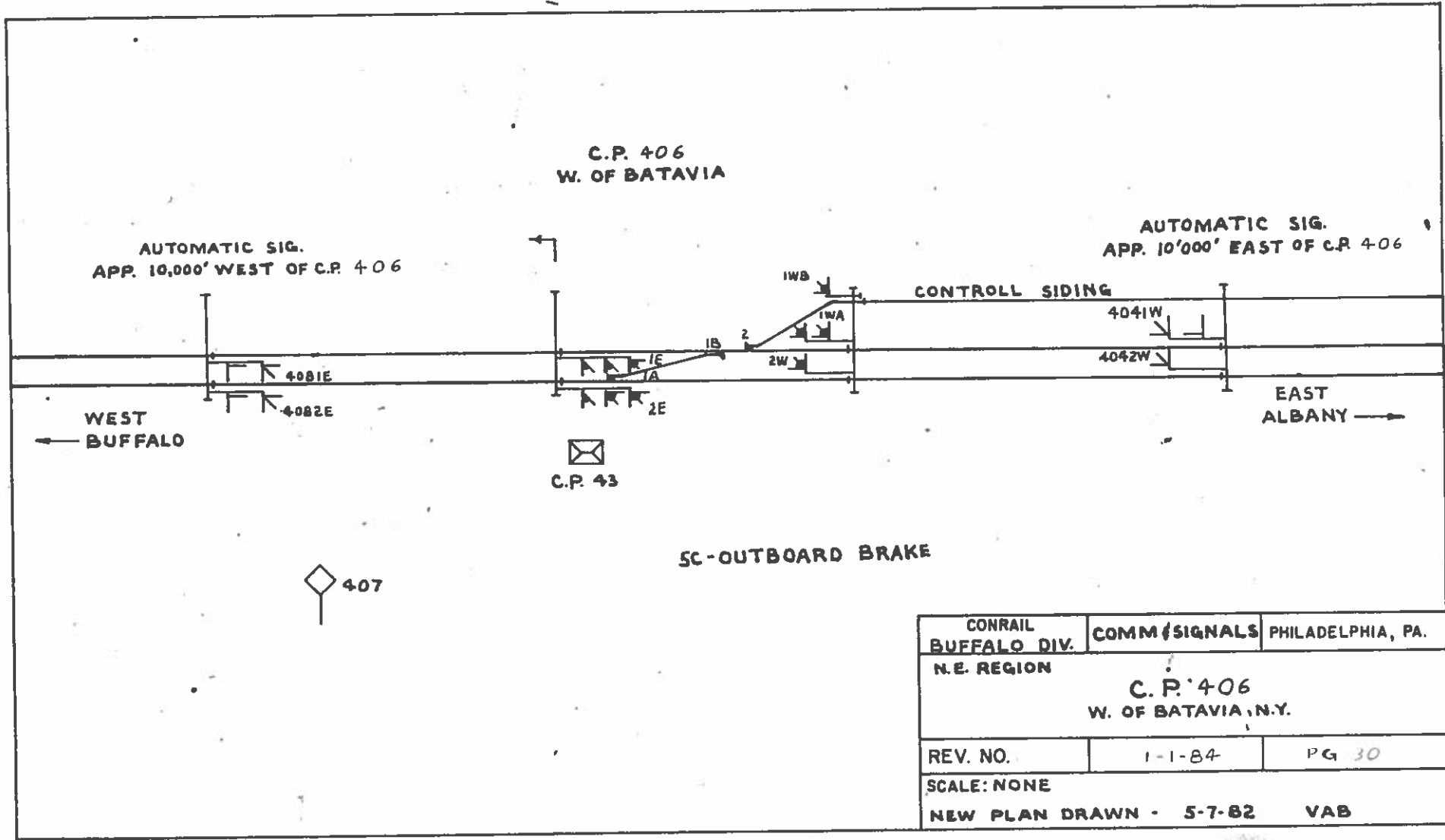

CONRAIL BUFFALO DIV.	COMM/SIGNALS	PHILADELPHIA, PA.
N.E. REGION		
C. P. 406 W. OF BATAVIA, N.Y.		
REV. NO.	1-1-84	PG 30
SCALE: NONE		
NEW PLAN DRAWN - 5-7-82		
		VAB

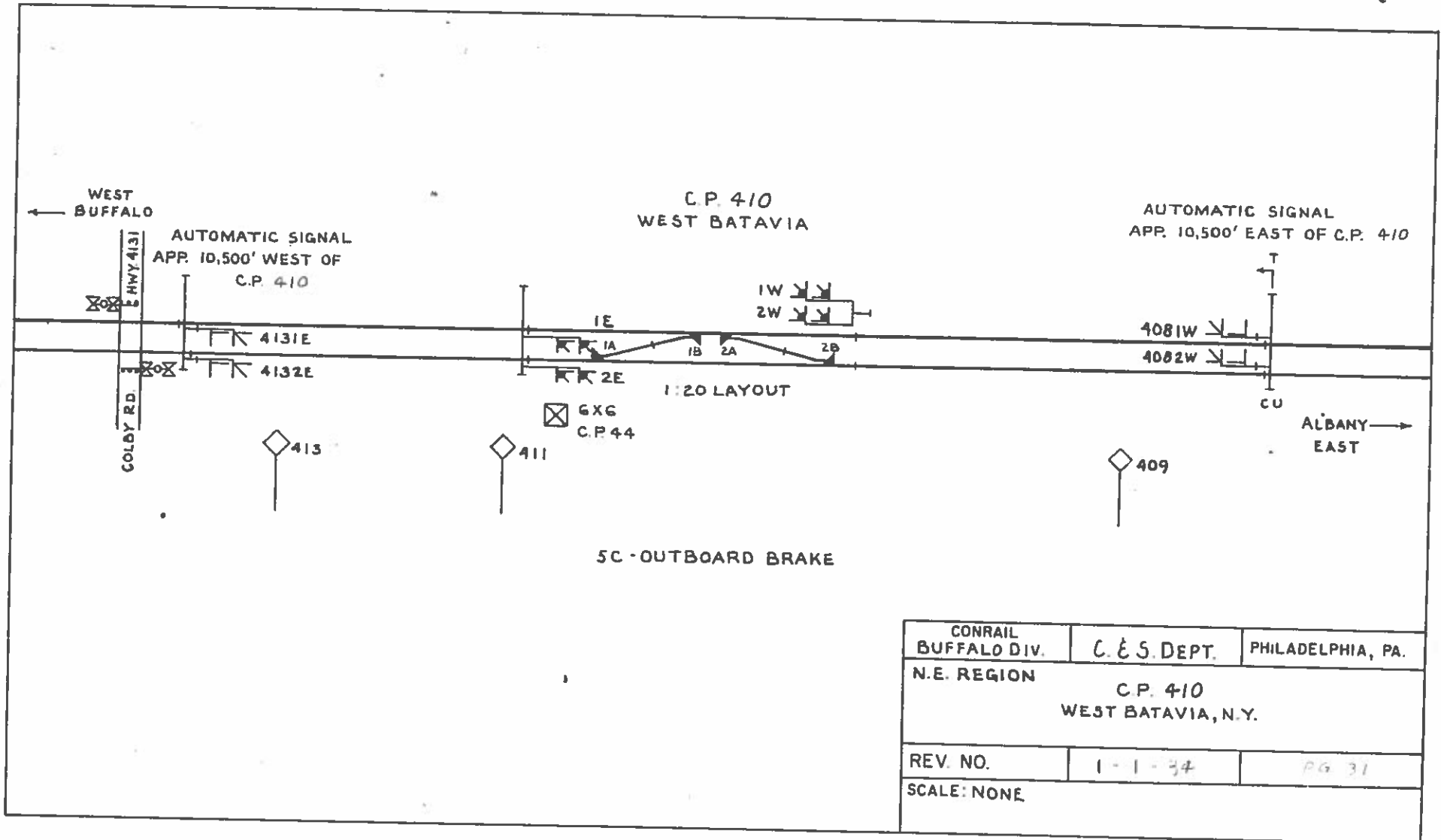

CONRAIL BUFFALO DIV.	C. E. S. DEPT.	PHILADELPHIA, PA.
N.E. REGION		C.P. 410 WEST BATAVIA, N.Y.
REV. NO.	1-1-34	PG 31
SCALE: NONE		

C.P. 415
W. OF CORFU

THIS HOME SIGNAL IS
APP. 11,000' WEST OF C.P. 415

THIS AUTOMATIC SIGNAL
IS APP. 11,000' EAST OF C.P. 415

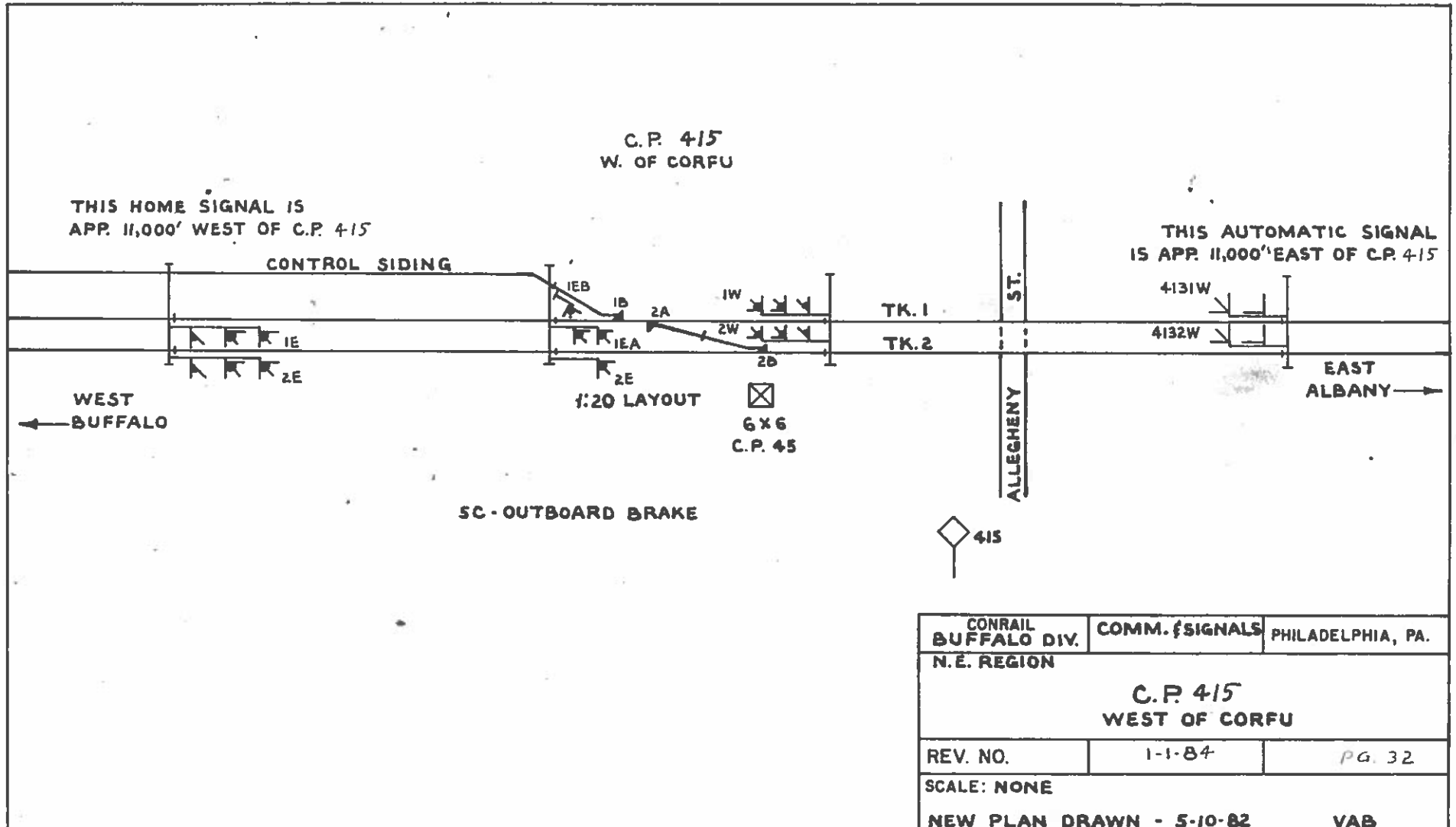

CONRAIL BUFFALO DIV.	COMM. SIGNALS	PHILADELPHIA, PA.
N.E. REGION		
C.P. 415 WEST OF CORFU		
REV. NO.	1-1-84	PG. 32
SCALE: NONE		
NEW PLAN DRAWN - 5-10-82		VAB

C.P. 417
EAST OF CRITTENDEN, N.Y.

THIS AUTOMATIC SIG. IS
APP. 9,000' WEST OF C.P. 417

THIS HOME SIGNAL
IS APP. 11,000' EAST OF
C.P. 417

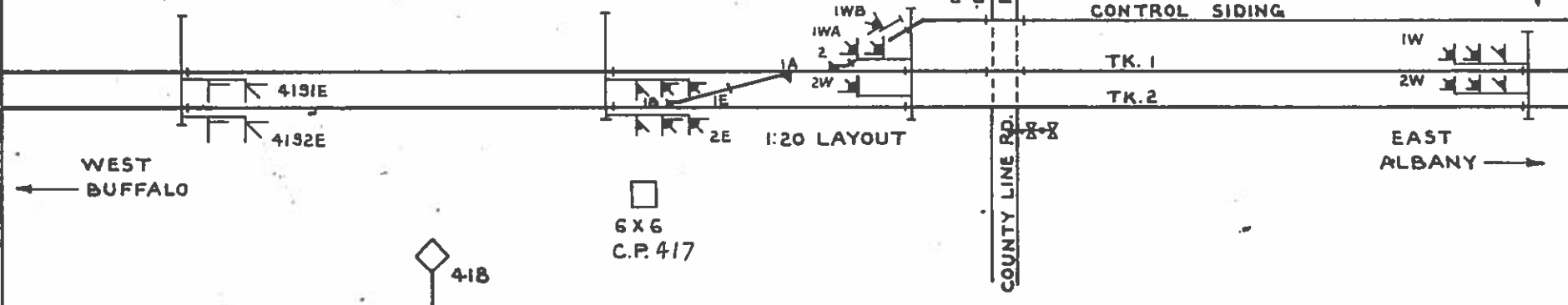

SC-OUTBOARD BRAKE

CONRAIL BUFFALO DIV.	COMM. SIGNALS	PHILADELPHIA, PA.
N.E. REGION		
C.P. 417		
EAST OF CRITTENDEN, N.Y.		
REV. NO.	1-1-84	PG 33
SCALE: NONE		
NEW PLAN DRAWN - 5-10-82		VAB

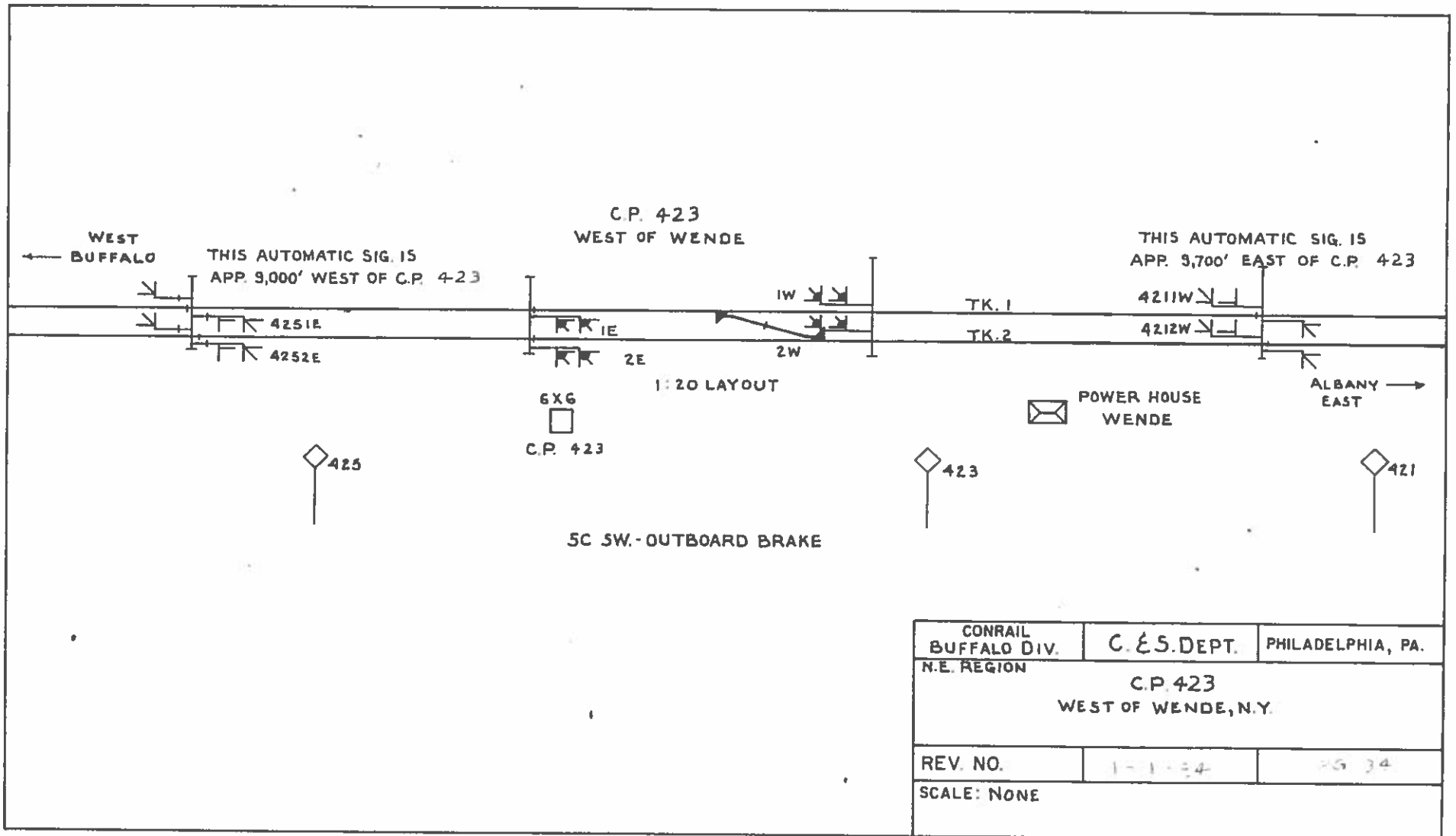

CONRAIL BUFFALO DIV. N.E. REGION	C. & S. DEPT.	PHILADELPHIA, PA.
C.P. 423 WEST OF WENDE, N.Y.		
REV. NO.	1-1-84	PG 34
SCALE: NONE		

C.P. 429
 DEPEW
 REMOTE CONTROL FROM
 DISP. OFFICE

THIS SIGNAL LOCATION
 IS APP. 6,200' WEST OF C.P. 429

THIS AUTOMATIC SIG. IS
 APP. 11,000' EAST OF C.P. 429

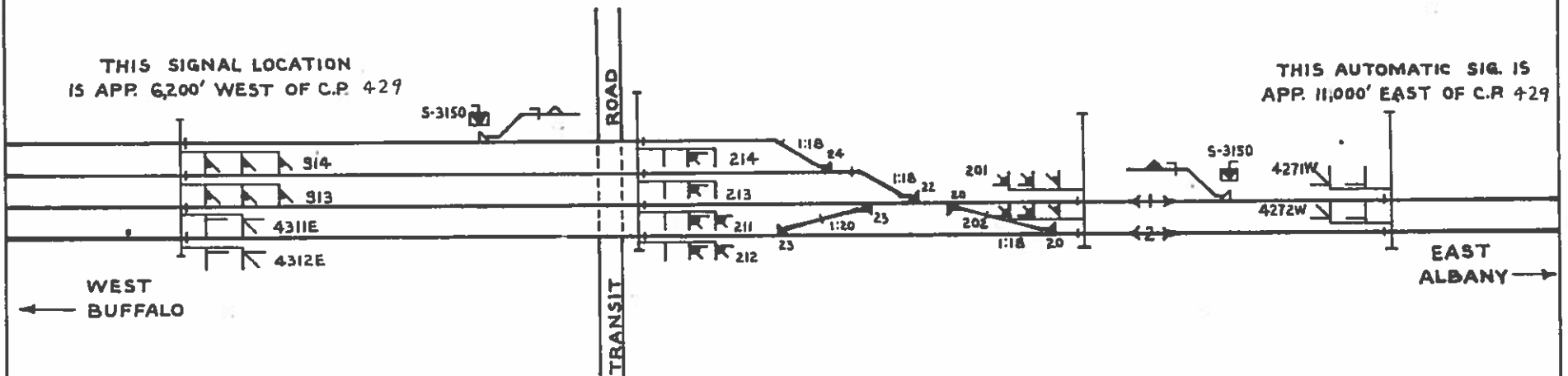

WEST
 BUFFALO ←

→ EAST
 ALBANY

◇ 430

5H SW.

CONRAIL BUFFALO DIV.	COMM. SIGNALS	PHILADELPHIA, PA.
N. E. REGION		
C.P. 429 DEPEW, N.Y.		
REV. NO.	1-1-84	PG 35
SCALE: NONE		
NEW PLAN DRAWN - 5-10-82		VAB

C.P. 431
 DEPEW
 REMOTE CONTROL FROM
 DISP. OFFICE

THIS HOME SIG. IS
 APPR 8,600' WEST OF CP 431

THIS HOME SIG. IS
 APPR 6,000' EAST OF C.P. 431

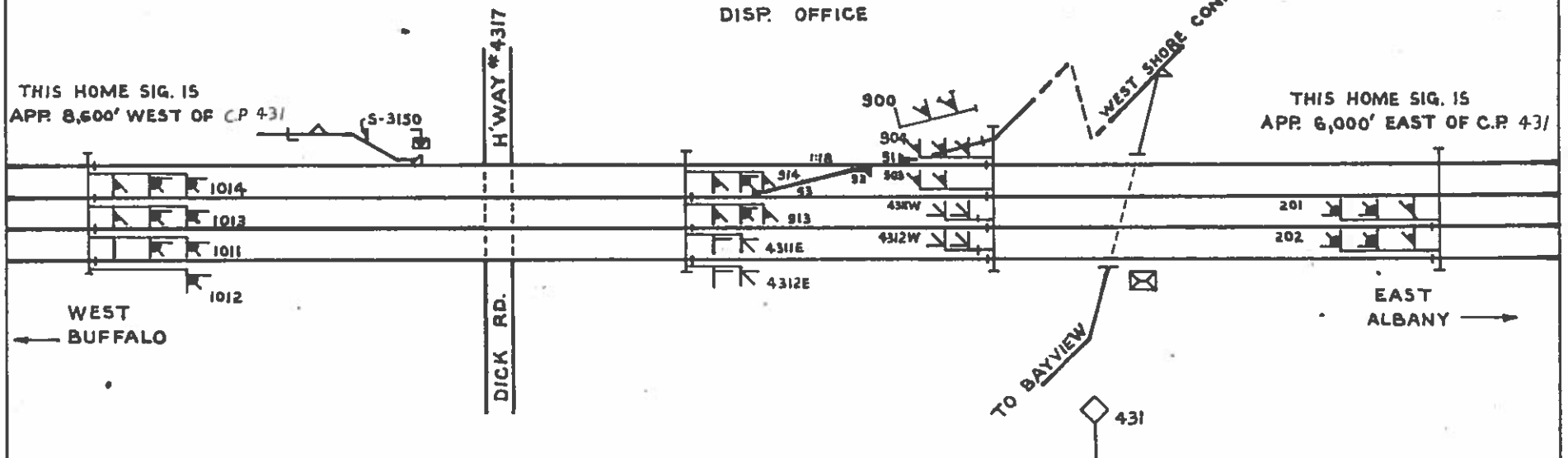

5A - OUTBOARD BRAKE

CONRAIL BUFFALO DIV.	COMM. & SIGNALS	PHILADELPHIA, PA.
N. E. REGION		
C. P. 431 DEPEW, N. Y.		
REV. NO.	1-1-84	PG 36
SCALE: NONE		
NEW PLAN DRAWN - 5-11-82		YAB

C.P. 433
 UNION RD. BUFFALO
 REMOTE CONTROL FROM
 DISP. OFFICE

THIS HOME SIG. IS
 APP. 7,000' WEST OF C.R. 4-33

THIS SIGNAL
 LOCATION IS APP.
 8,000' EAST
 OF C.R. 4-33

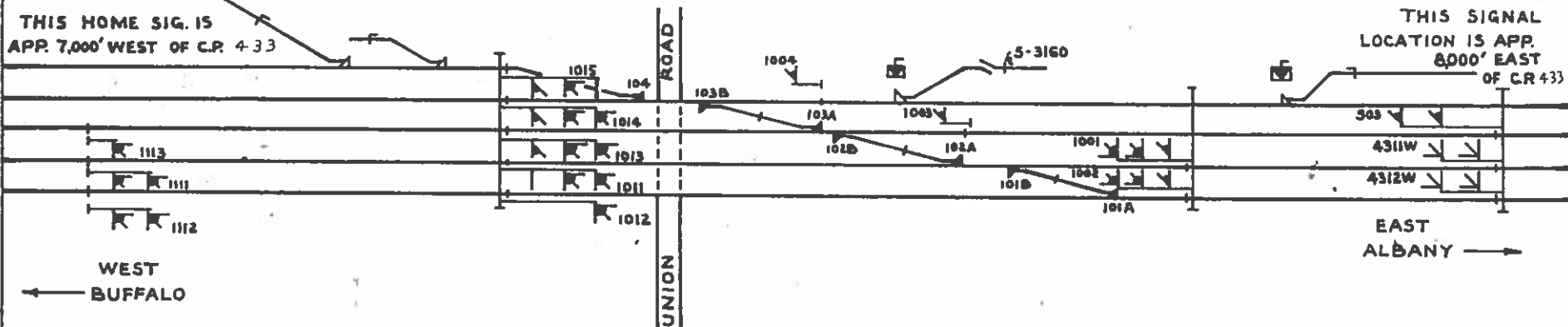

WEST
 BUFFALO ←

EAST
 ALBANY →



101, 102, 103A - 5H SW.
 104 + 103B - 5C OUTBOARD BRAKE

CONRAIL BUFFALO DIV.	COMM. # SIGNALS	PHILADELPHIA, PA.
N. E. REGION		
C. P. 433 UNION ROAD BUFFALO, N.Y.		
REV. NO.	1-1-84	PG. 37
SCALE: NONE		
NEW PLAN DRAWN - 5-11-82		VAB

C.P. 434
 HARLEM AVE. BUFFALO
 REMOTE CONTROL FROM
 DISP. OFFICE

THIS HOME SIGNAL IS
 APP. 7,400' EAST OF C.P. 434

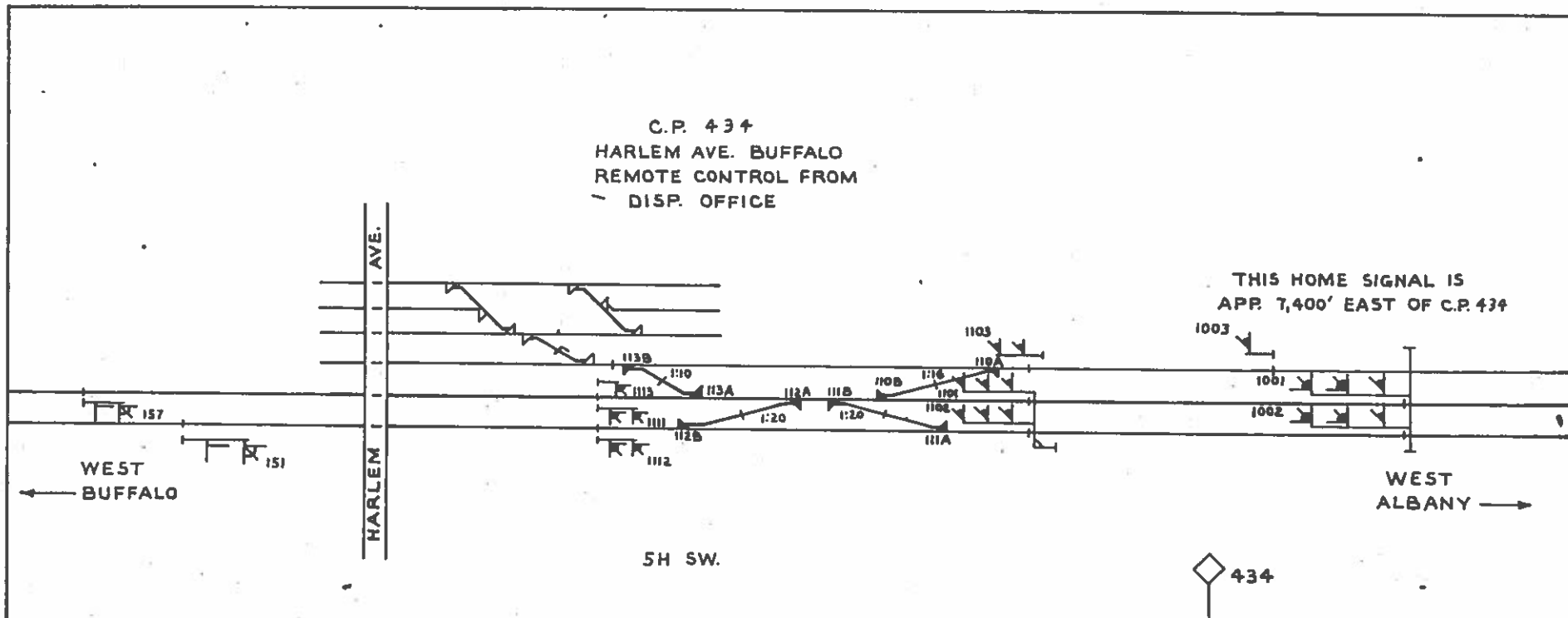

CONRAIL BUFFALO DIV.	COMM. SIGNALS	PHILADELPHIA, PA.
N.E. REGION		
C.P. 434 HARLEM AVE. BUFFALO, N.Y.		
REV. NO.	1-1-B4	PG 38
SCALE: NONE		
NEW PLAN DRAWN	5-11-82	VAB

INT 47
BUFFALO

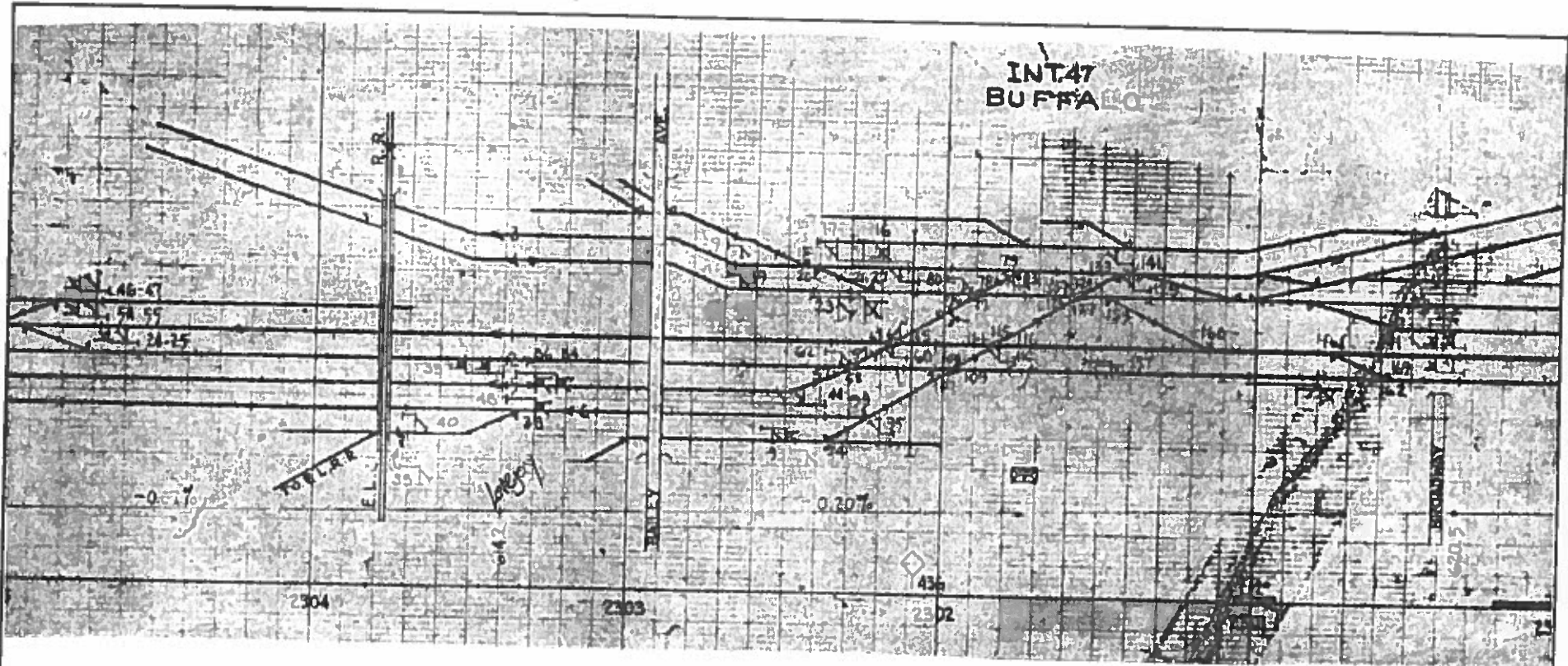

CONRAIL NORTHEASTERN	C & S DEPT.	PHILADELPHIA, PA.
BUFFALO DIV.		
S.S. 47 BUFFALO TERMINAL		
REV. NO.	DATE 1-1-84	PG 39
SCALE:		

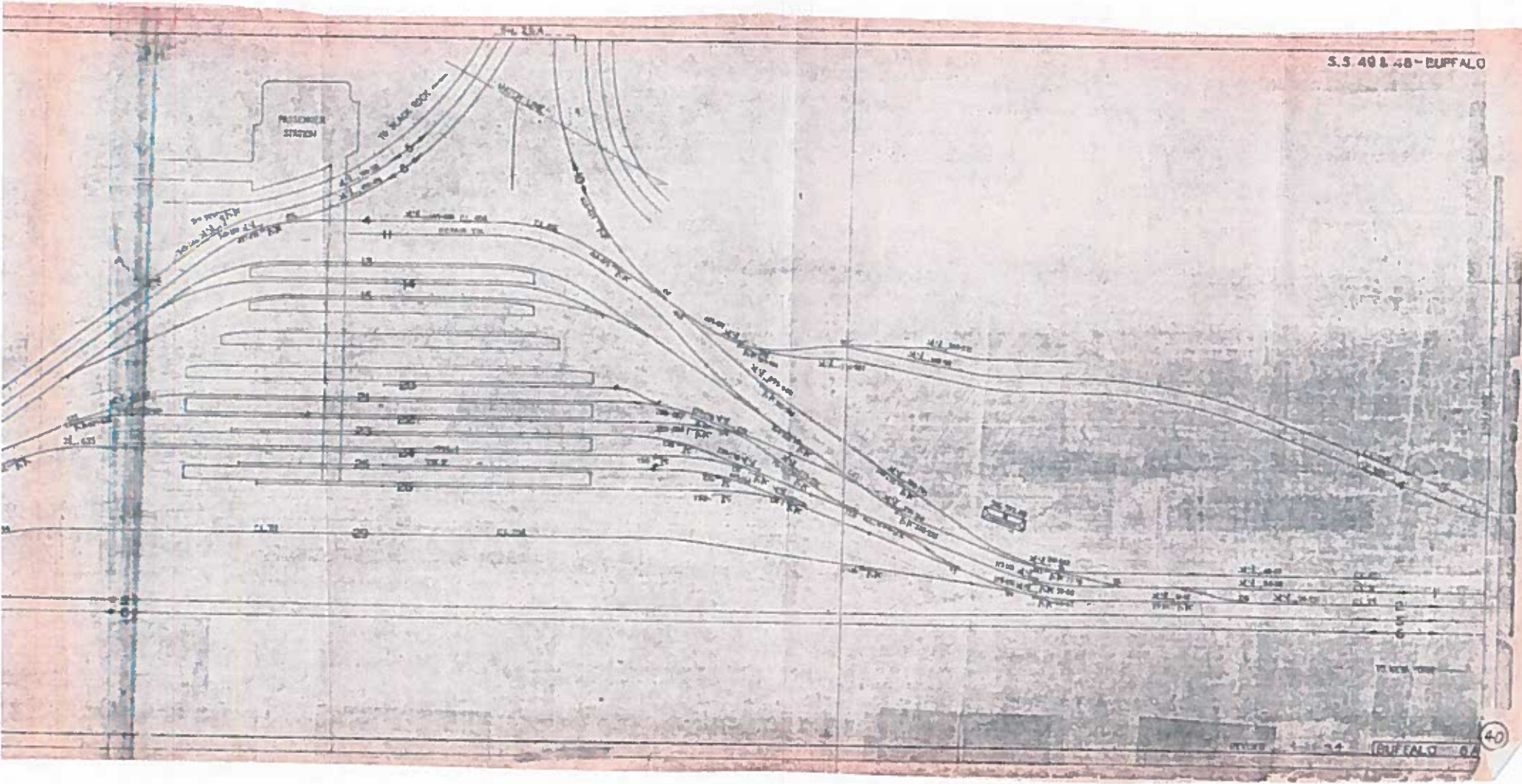

SCALE 1"=100'

Aug. 20
Completed

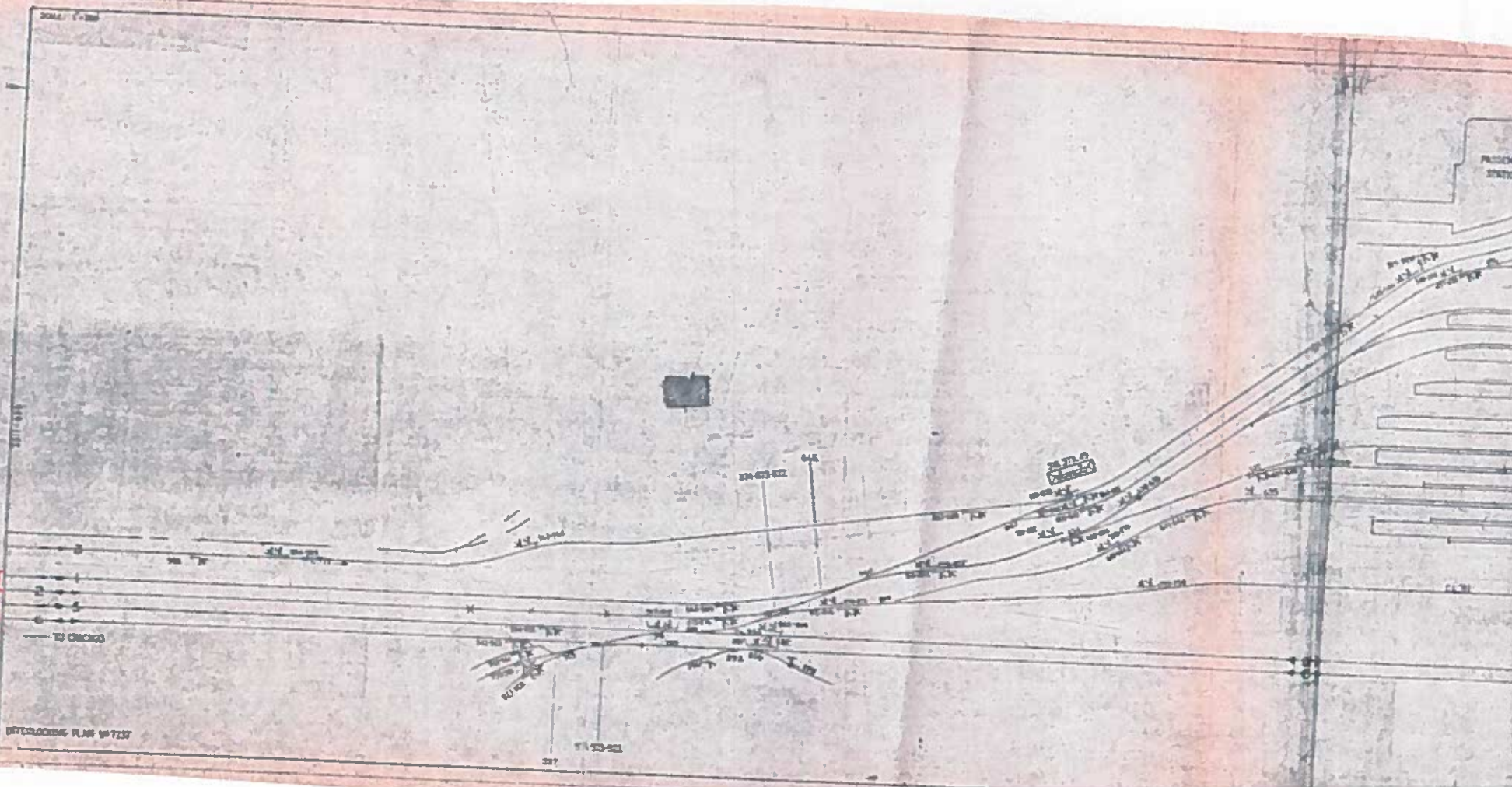

INTERLOCKING PLAN 107237

PULLMAN
STATION

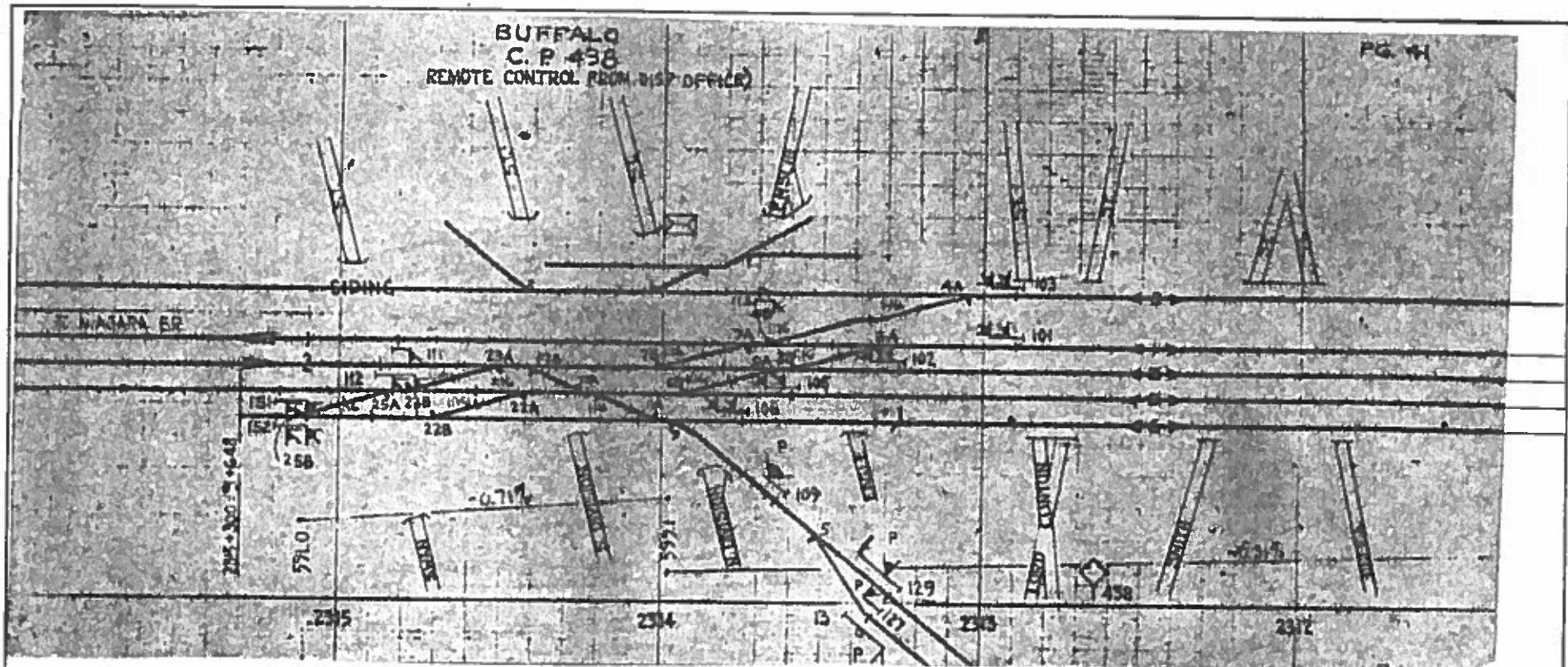

CONRAIL NORTHEASTERN		C&S DEPT.	PHILADELPHIA, PA.
BUFFALO DIV			
C.P. 438 BUFFALO TERMINAL			
REV. NO.	DATE	1-1-84	PG 41
SCALE:			

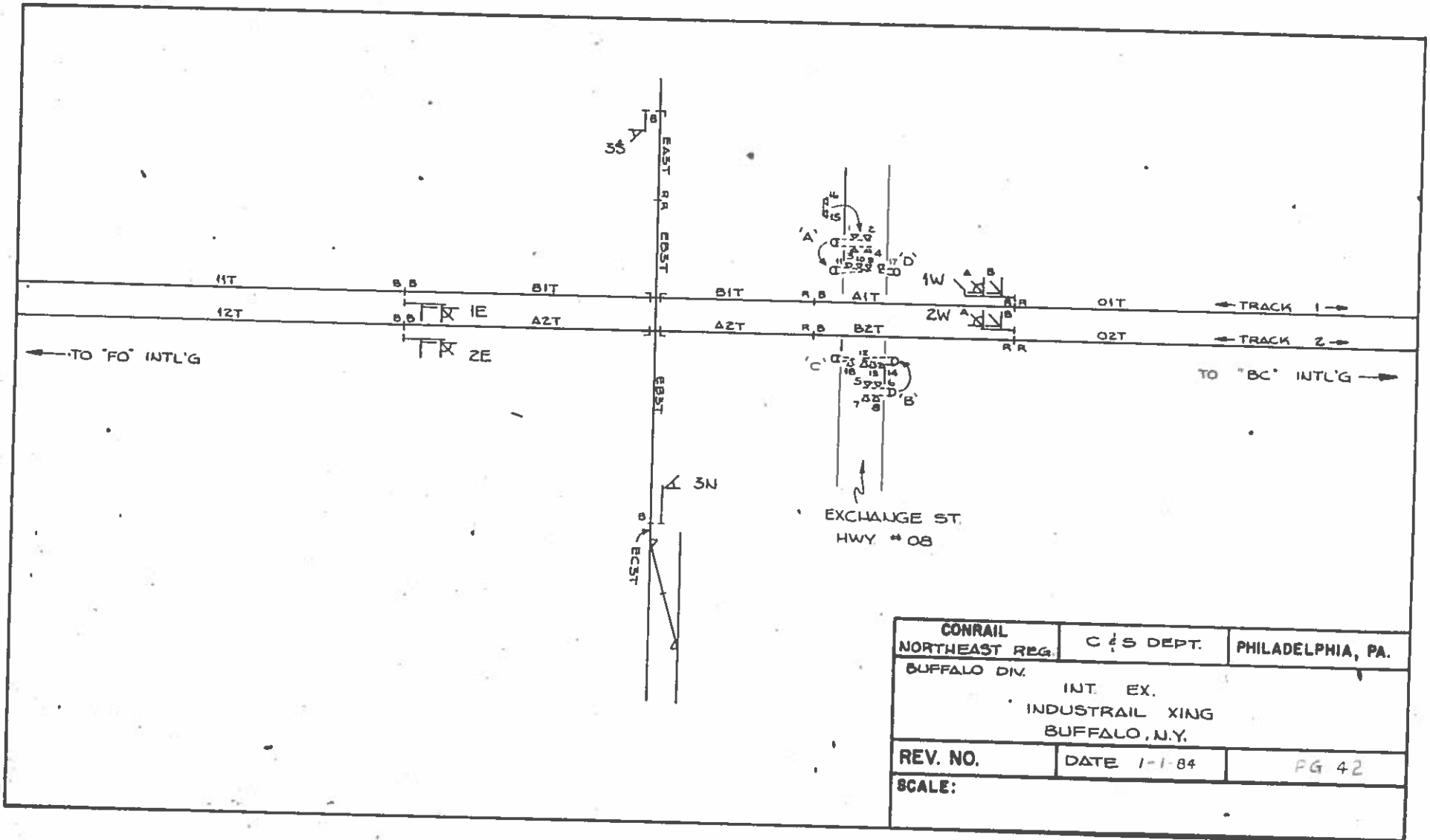

CONRAIL NORTHEAST REG.	C & S DEPT.	PHILADELPHIA, PA.
BUFFALO DIV.		
INT. EX. INDUSTRIAL XING BUFFALO, N.Y.		
REV. NO.	DATE 1-1-84	PG 42
SCALE:		

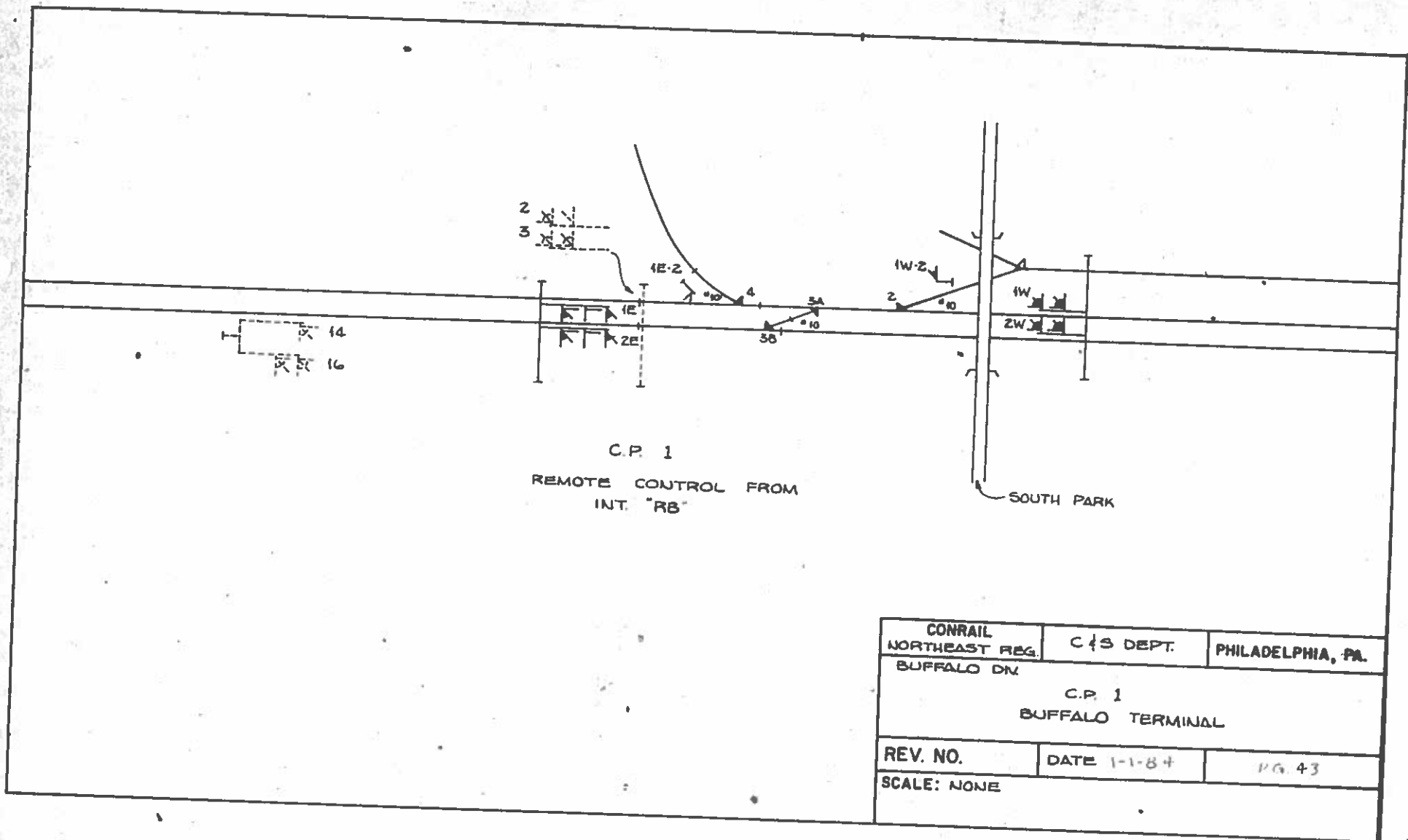

CONRAIL NORTHEAST REG.	C+S DEPT.	PHILADELPHIA, PA.
BUFFALO DIV.		
C.P. 1 BUFFALO TERMINAL		
REV. NO.	DATE 1-1-84	PG. 43
SCALE: NONE		

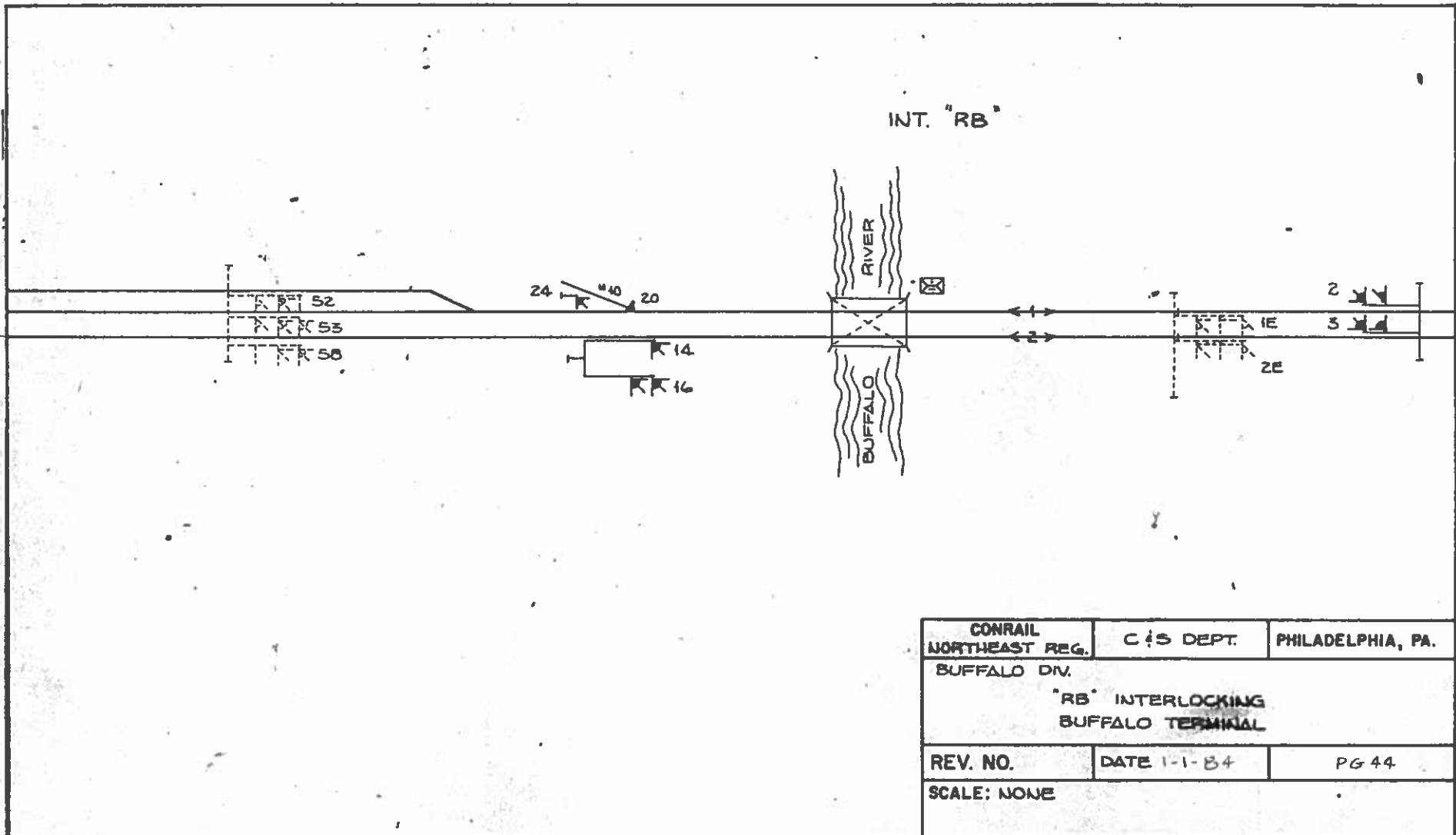

CONRAIL NORTHEAST REG.	C & S DEPT.	PHILADELPHIA, PA.
BUFFALO DIV.		
"RB" INTERLOCKING BUFFALO TERMINAL		
REV. NO.	DATE 1-1-84	PG 44
SCALE: NONE		

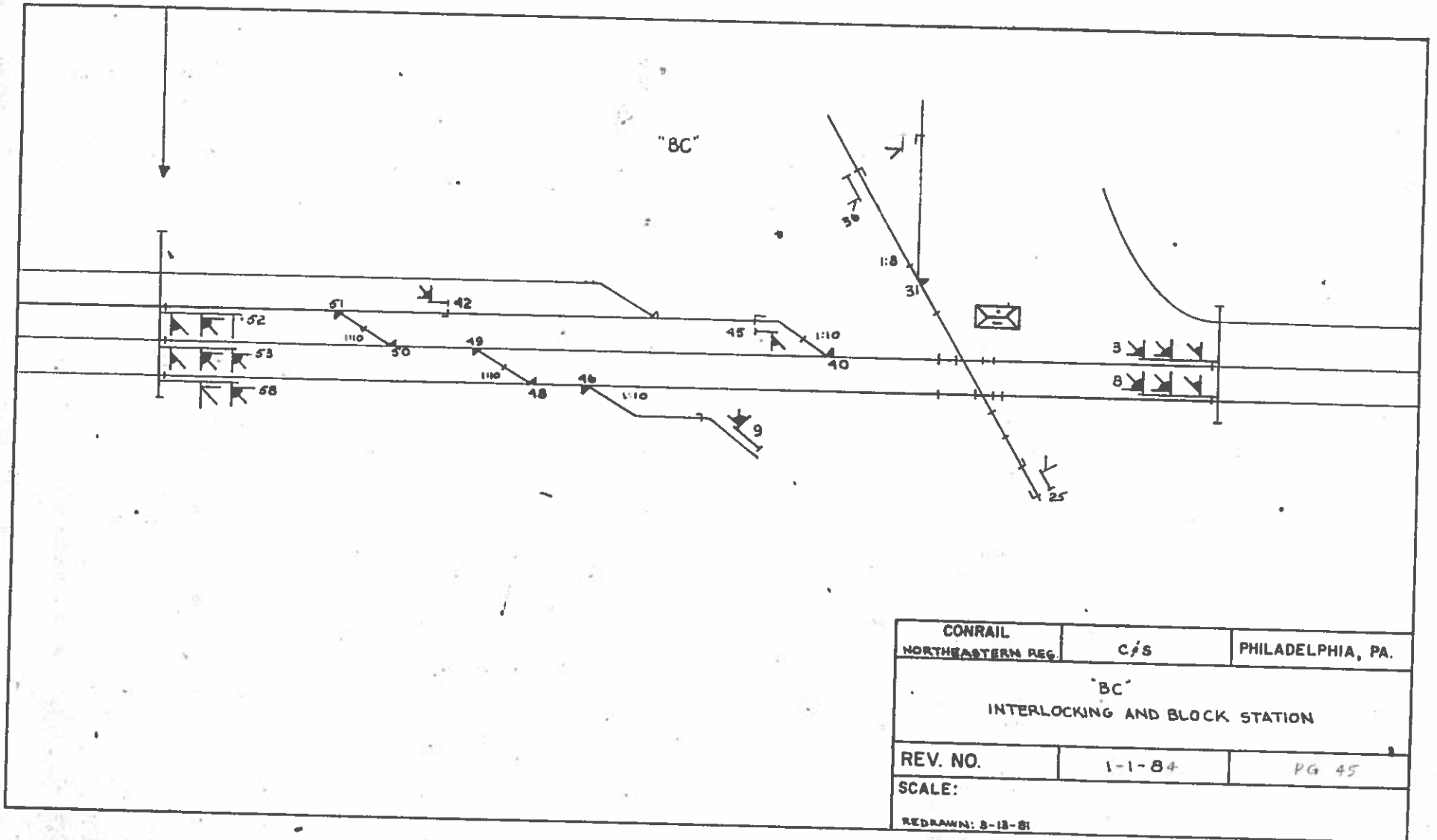

CONRAIL NORTHEASTERN REG.	<i>cjs</i>	PHILADELPHIA, PA.
"BC" INTERLOCKING AND BLOCK STATION		
REV. NO.	1-1-84	PG 45
SCALE:		
REDRAWN: 8-13-81		

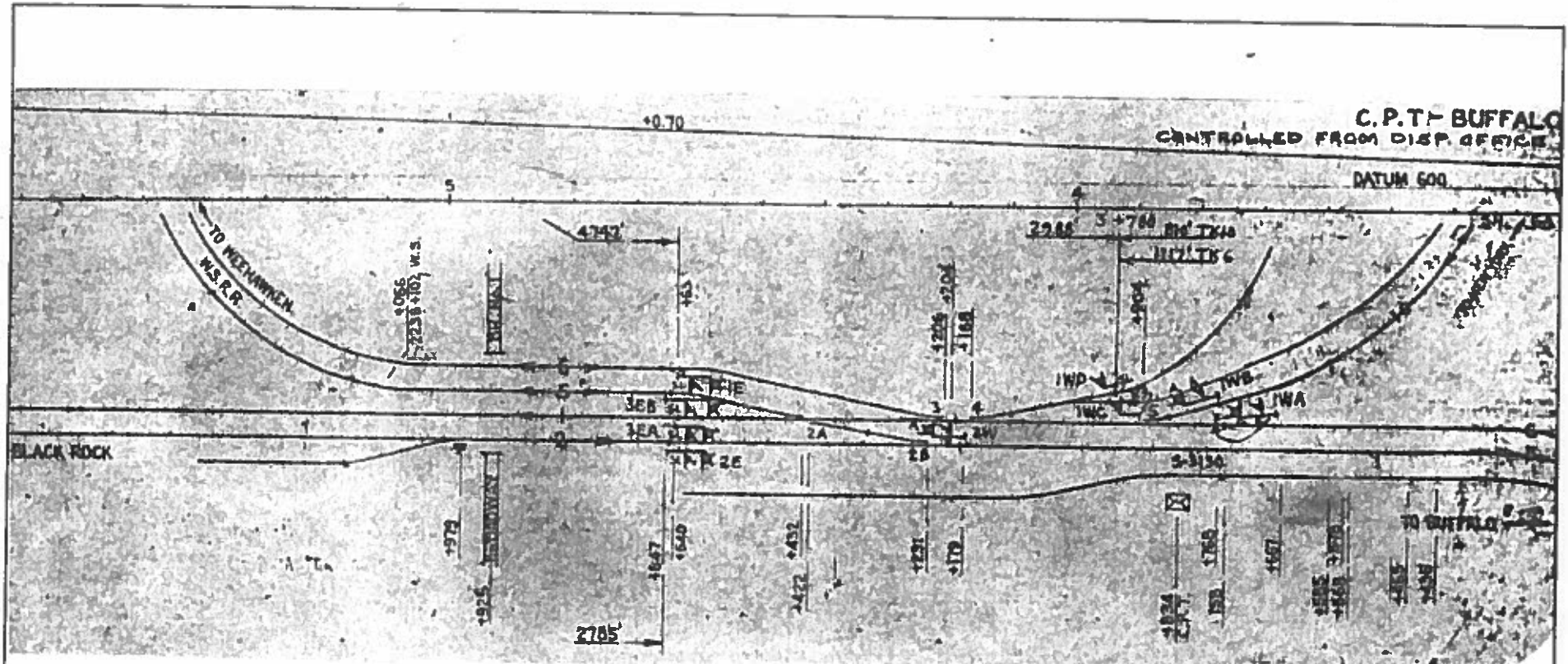

C. P. T. BUFFALO
 CONTROLLED FROM DISP. OFFICE
 DATUM 600

CONRAIL NORTHEASTERN BUFFALO DIV.	C & S DEPT	PHILADELPHIA, PA.
C. P. T. BUFFALO, N.Y.		
REV. NO.	DATE 11-1-54	19 46
SCALE:		

CONTROLLED FROM DISP. OFFICE

C.P. SYCAMORE ST.
BUFFALO

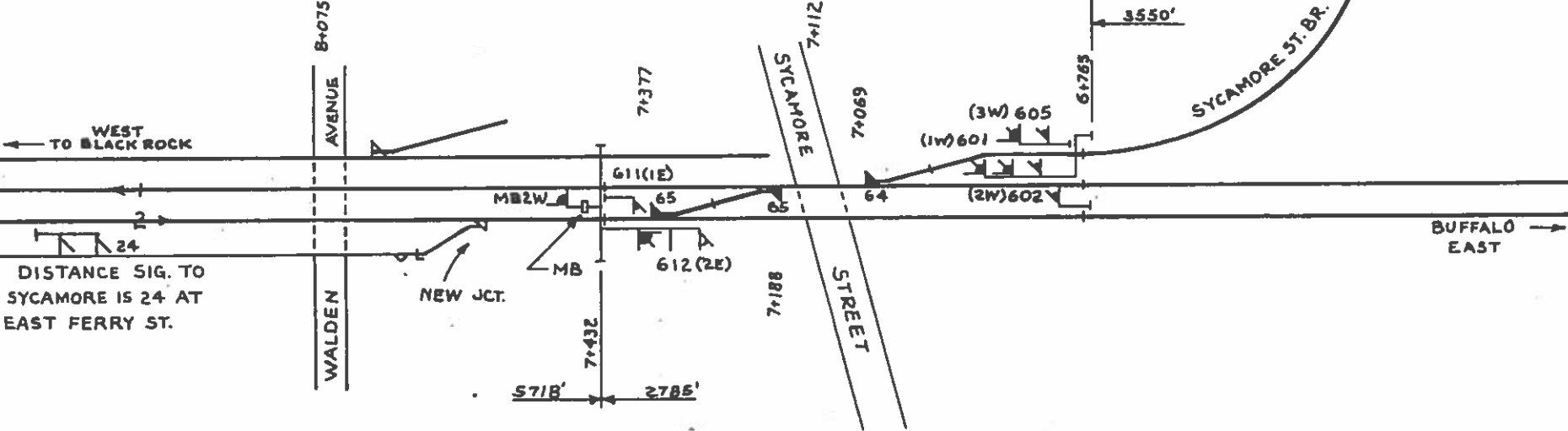

DISTANCE SIG. TO
SYCAMORE IS 24 AT
EAST FERRY ST.

CONRAIL BUFFALO DIV. N.E. REGION	C. & S. DEPT. C.P. SYCAMORE ST. BELT LINE BR. BUFFALO, N.Y.	PHILADELPHIA, PA.
REV. NO.	1-1-84	PG 47
SCALE: NONE		

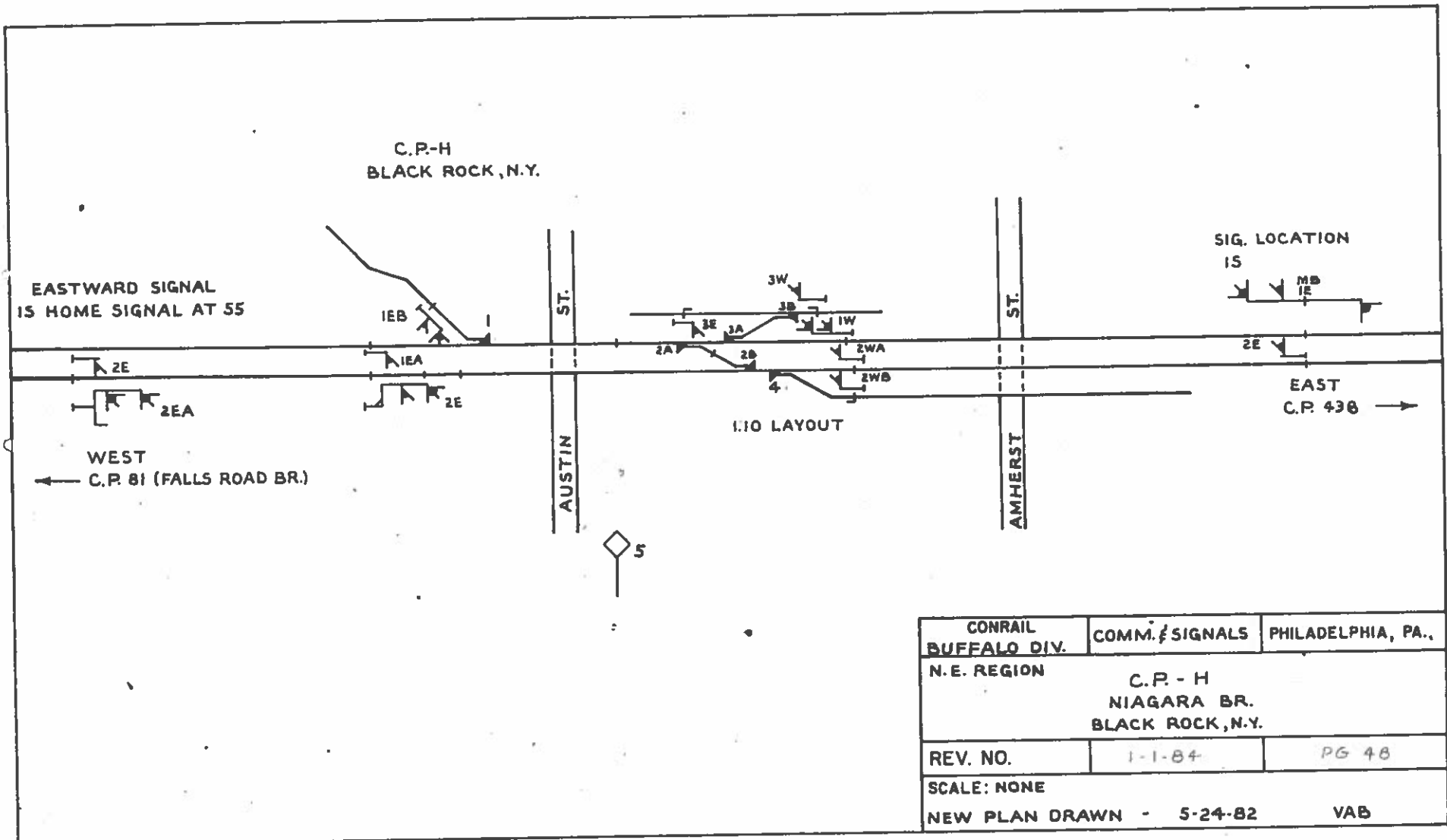

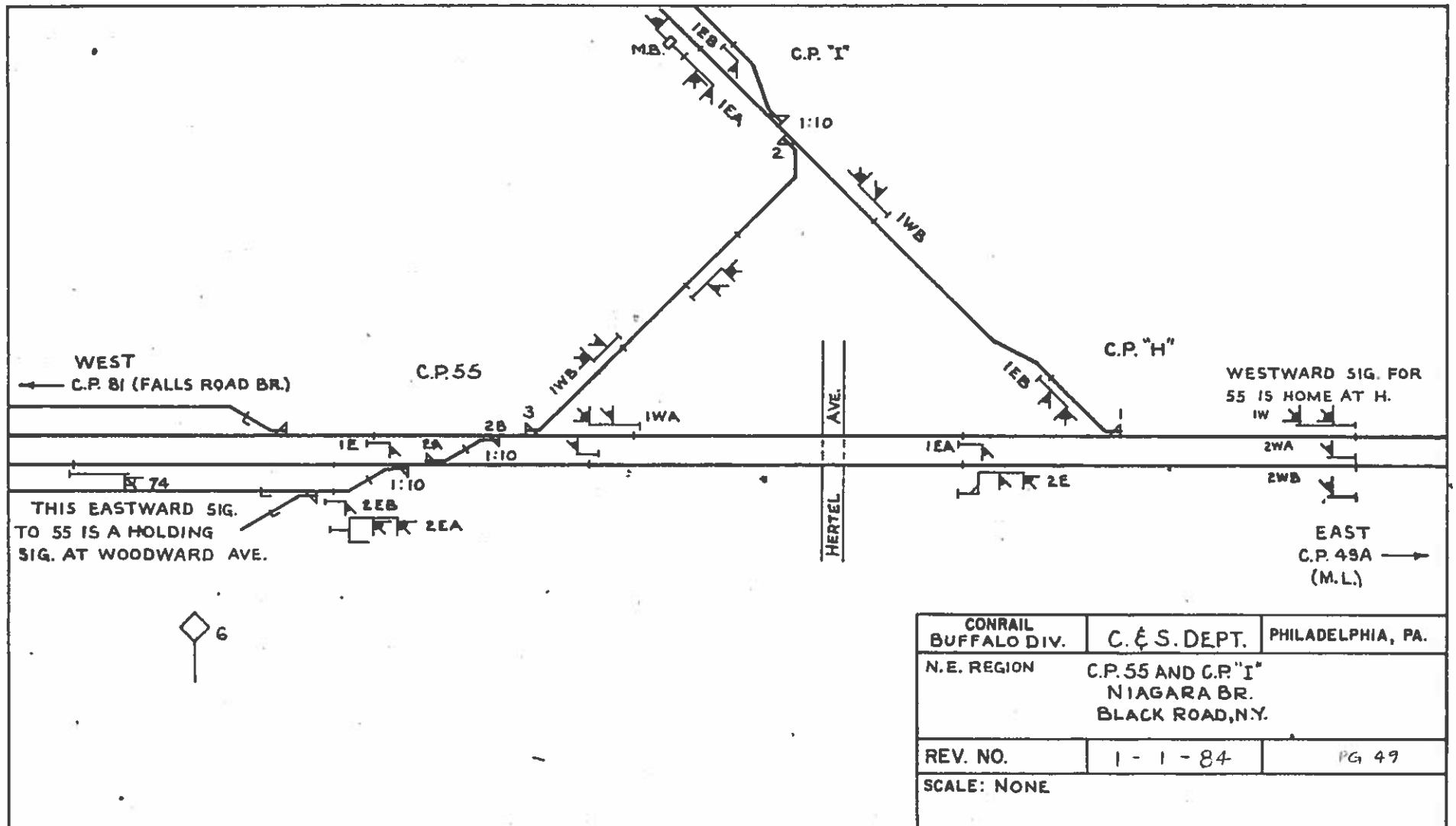

CONRAIL BUFFALO DIV.	C. & S. DEPT.	PHILADELPHIA, PA.
N. E. REGION	C.P. 55 AND C.P. "I" NIAGARA BR. BLACK ROAD, N.Y.	
REV. NO.	1 - 1 - 84	PG 49
SCALE: NONE		

C. P. 83
 MILITARY ROAD
 NIAGARA, N.Y.
 INTERLOCKING REMOTELY
 CONTROLLED FROM DISPATCHERS
 OFFICE, BUFFALO

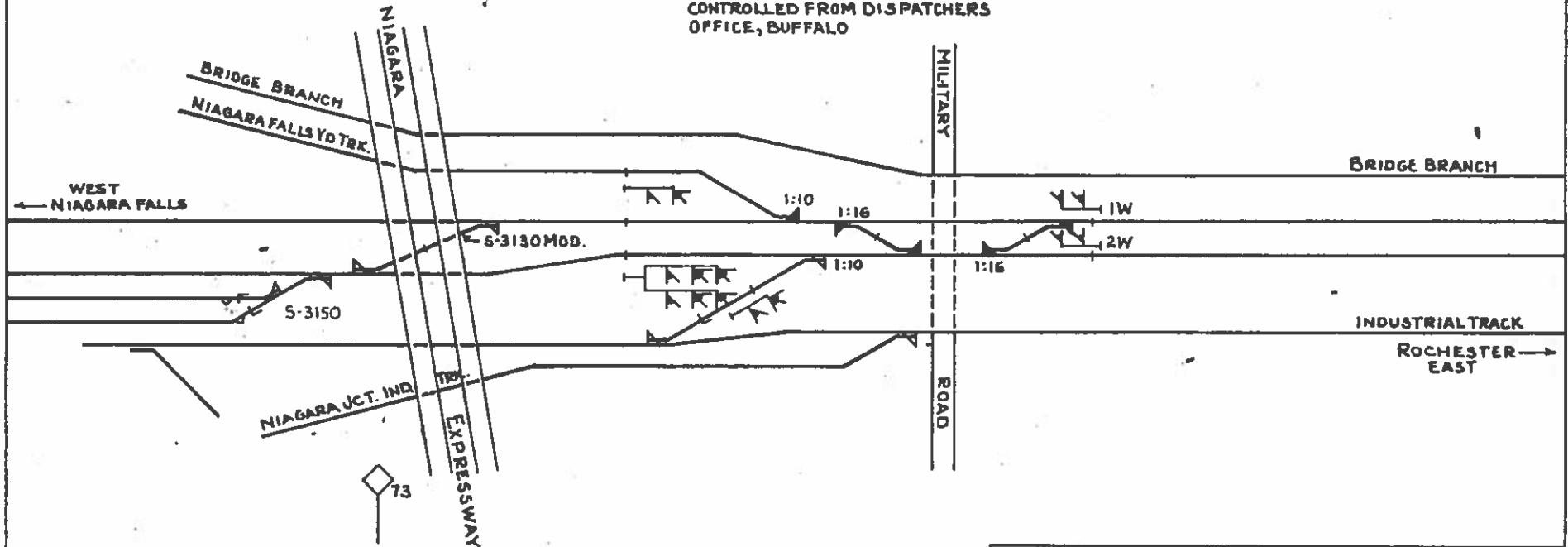

CONRAIL BUFFALO DIV.	C. & S. DEPT	PHILADELPHIA, PA.
N.E. REGION	C. P. 83 FALLS ROAD BR. NIAGARA, N.Y.	
REV. NO.	1-1-84	PG 50
SCALE: NONE		

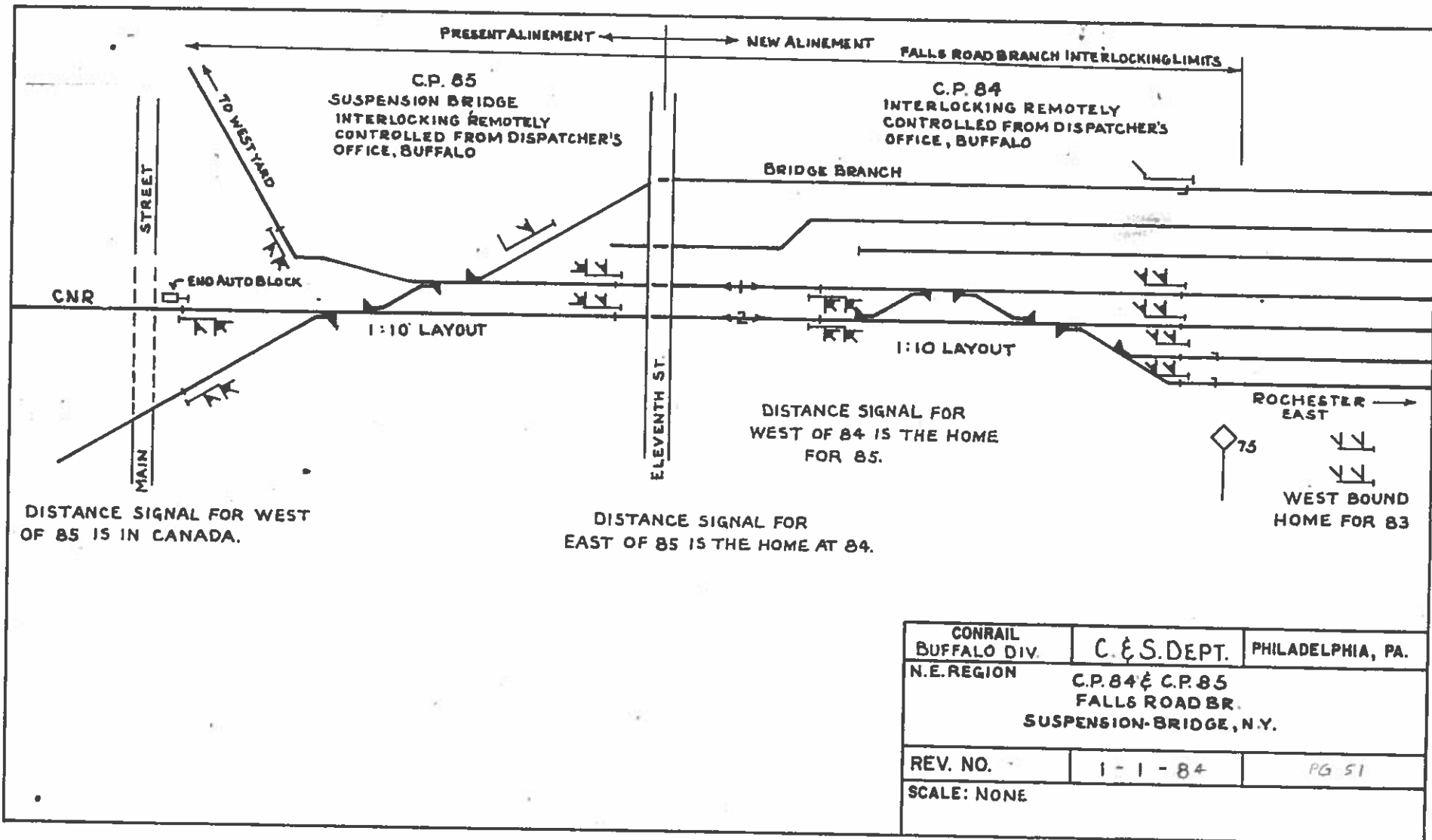

"CP EL-3"

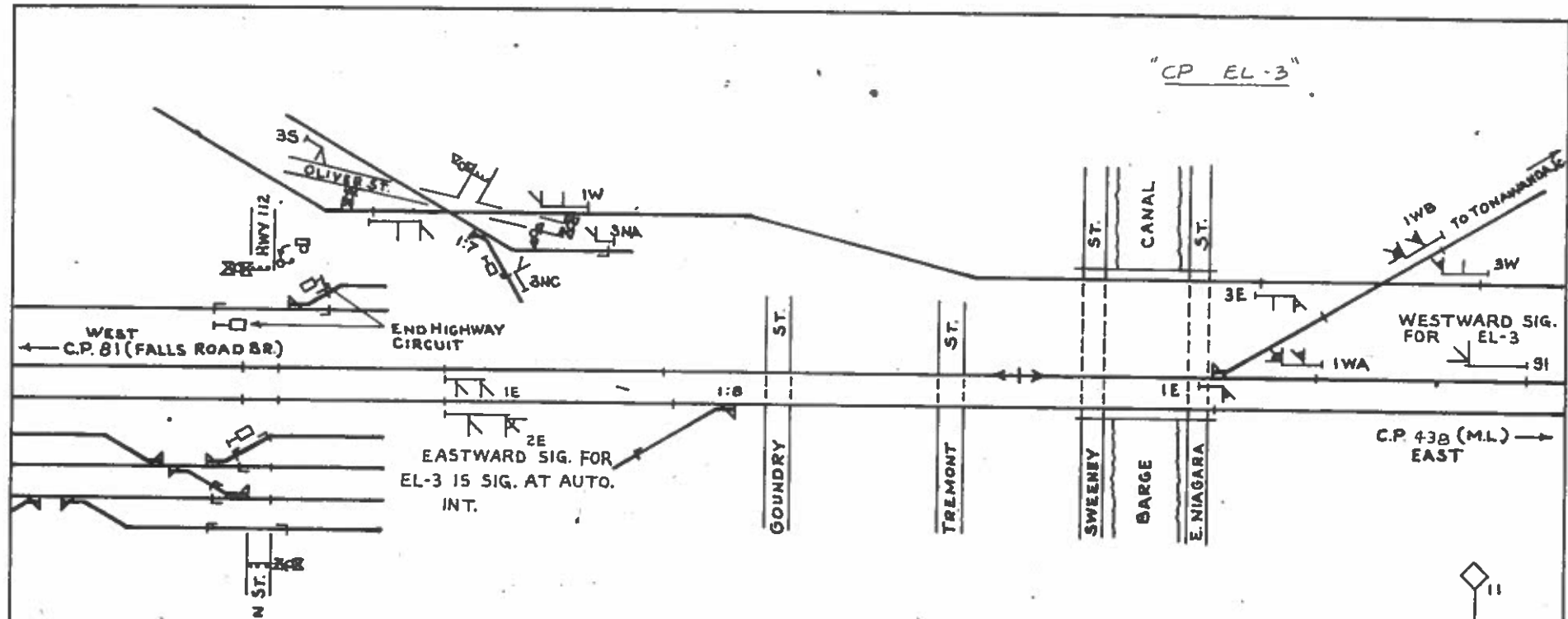

EASTWARD SIG. FOR
EL-3 IS SIG. AT AUTO.
INT.

NOTE: NO SERVICE ON THE
NIAGARA FALLS SEC.

CONRAIL BUFFALO DIV.	C. & S. DEPT.	PHILADELPHIA, PA.
N. E. REGION		
NIAGARA BR. NORTH TONAWANDA, N.Y.		
REV. NO.	1-1-84	PG 52
SCALE: NONE		

C.P. 60
WHEATFIELD
REMOTE CONTROLLED
FROM DIST. OFFICE

EASTWARD SIG. FOR 60 IS 16E
APPR. 1,500' WEST OF JAGOW RD.

WESTWARD SIG. FOR 60 IS
SIG. AT AUTO. INT. 59

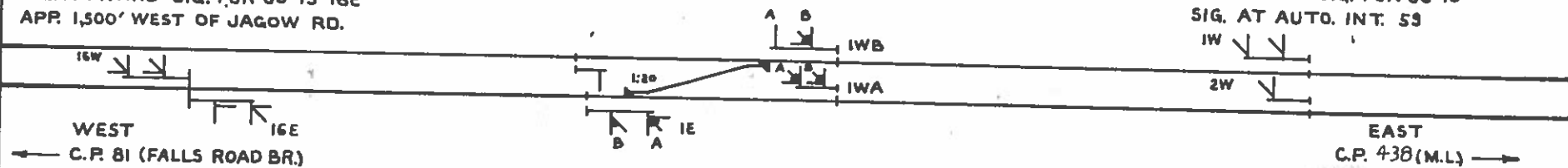

CONRAIL BUFFALO DIV.	COMM. & SIGNALS	PHILADELPHIA, PA.
N.E. REGION		
C. P. 60 NIAGARA BR. WHEATFIELD, N.Y.		
REV. NO.	1-1-84	PG 53
SCALE: NONE		
NEW PLAN DRAWN -		VAB

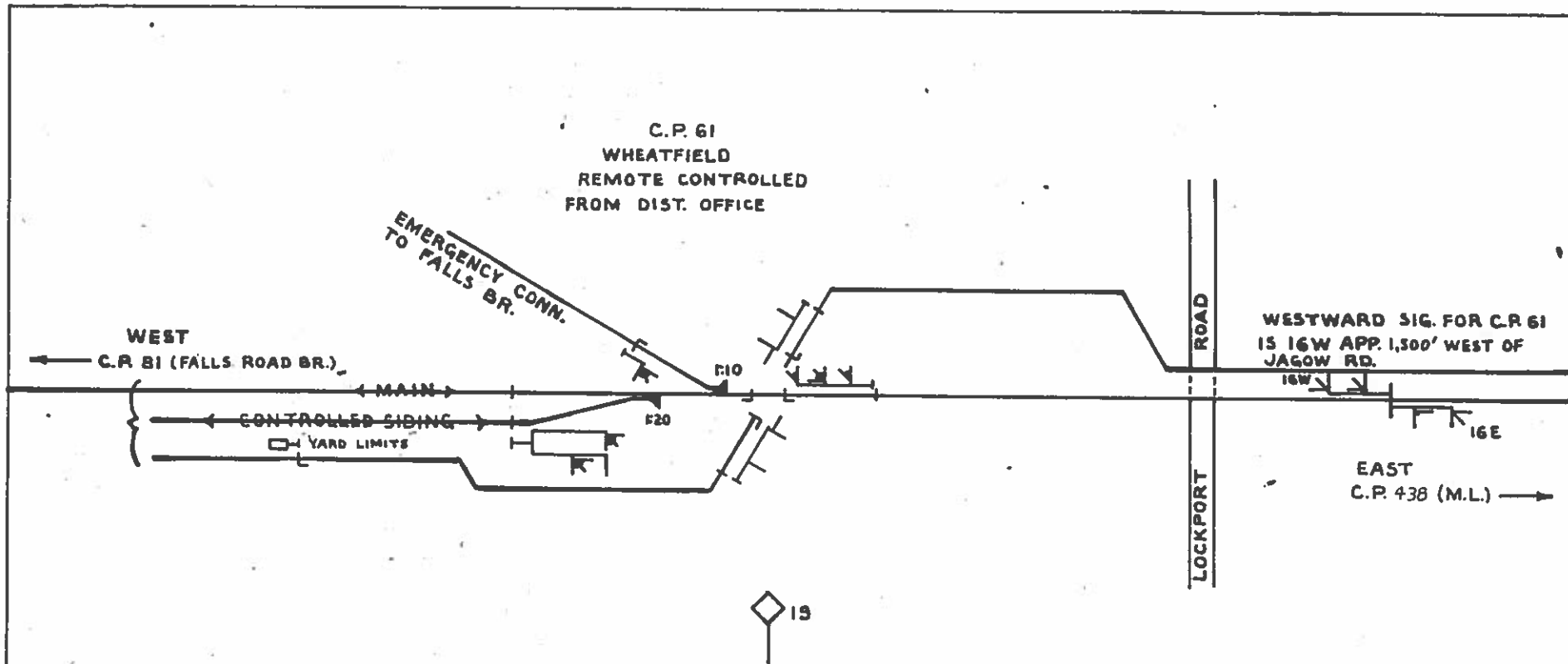

CONRAIL BUFFALO DIV. N.E. REGION	COMM. & SIGNALS	PHILADELPHIA, PA.
C.P. 61 NIAGARA BR. WHEATFIELD, N.Y.		
REV. NO.	1-1-84	PG 54
SCALE: NONE		
NEW PLAN DRAWN -		YAD

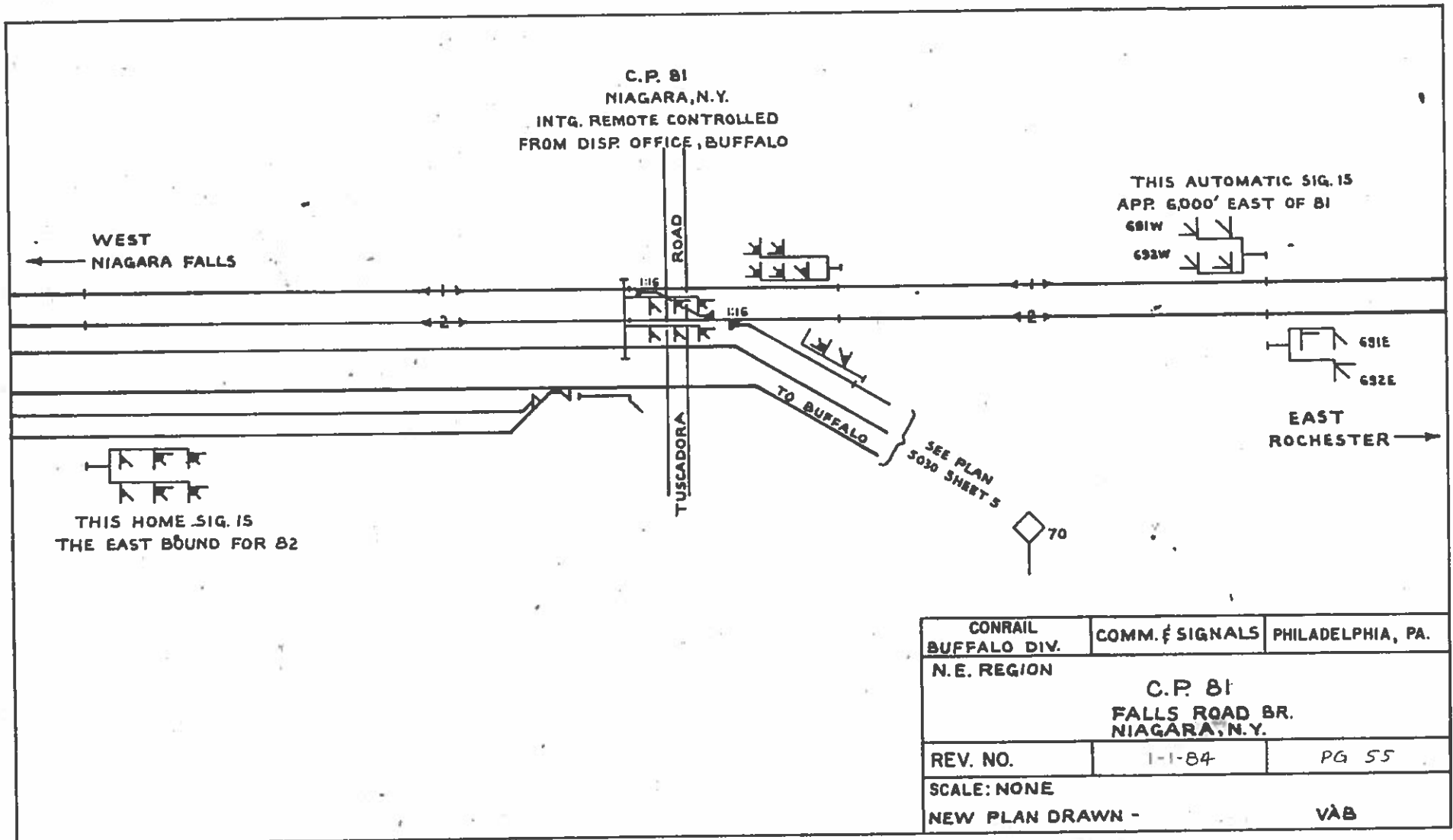

C.P. 81
 NIAGARA, N.Y.
 INTG. REMOTE CONTROLLED
 FROM DISP. OFFICE, BUFFALO

THIS AUTOMATIC SIG. 15
 APP. 6,000' EAST OF 81

WEST
 NIAGARA FALLS

THIS HOME SIG. 15
 THE EAST BOUND FOR 82

EAST
 ROCHESTER

CONRAIL BUFFALO DIV.	COMM. & SIGNALS	PHILADELPHIA, PA.
N.E. REGION		
C.P. 81 FALLS ROAD BR. NIAGARA, N.Y.		
REV. NO.	1-1-84	PG 55
SCALE: NONE		VAB
NEW PLAN DRAWN -		

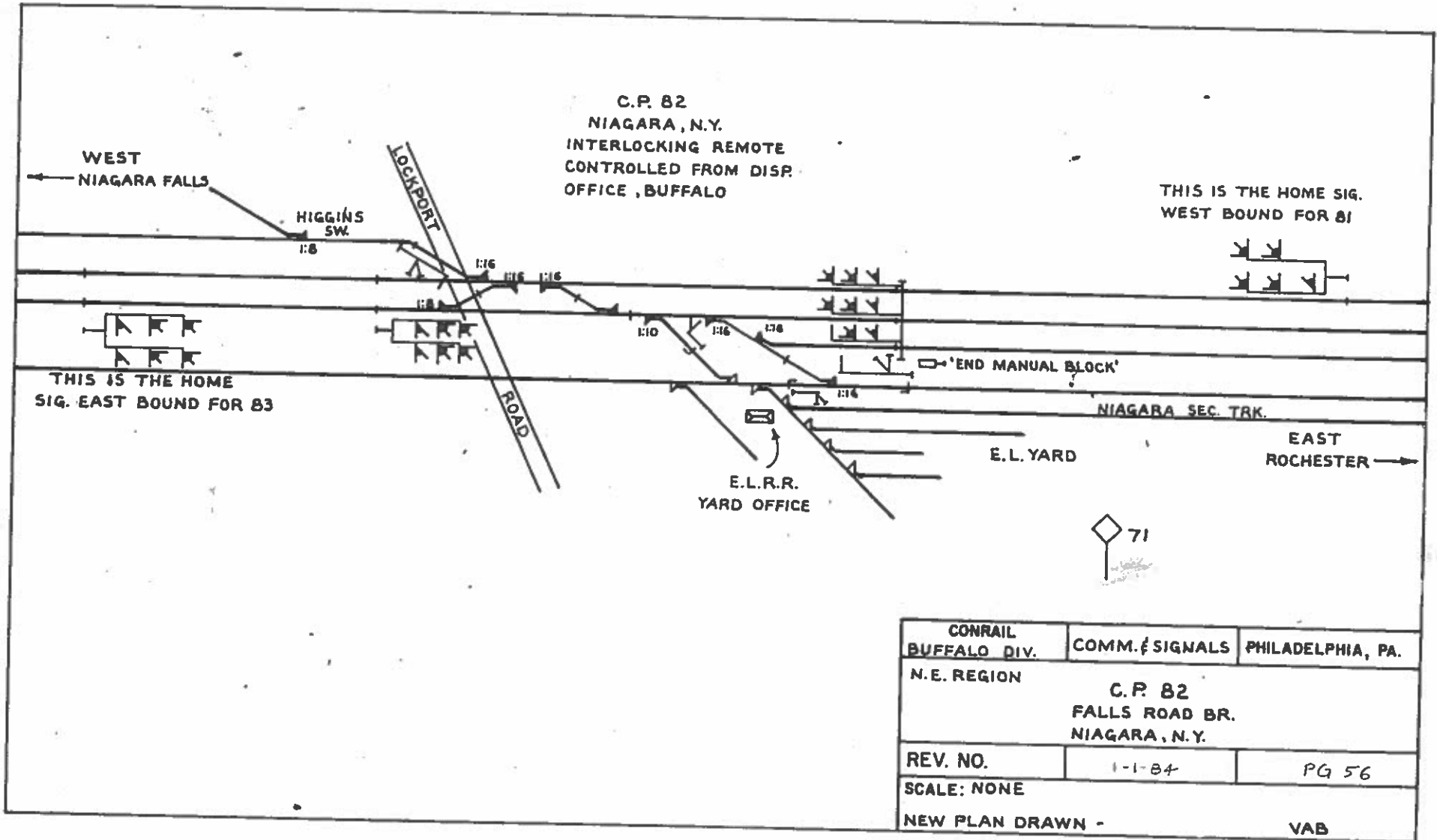

CONRAIL BUFFALO DIV.	COMM. & SIGNALS	PHILADELPHIA, PA.
N.E. REGION		
C.P. 82 FALLS ROAD BR. NIAGARA, N.Y.		
REV. NO.	1-1-84	PG 56
SCALE: NONE		
NEW PLAN DRAWN -		VAB

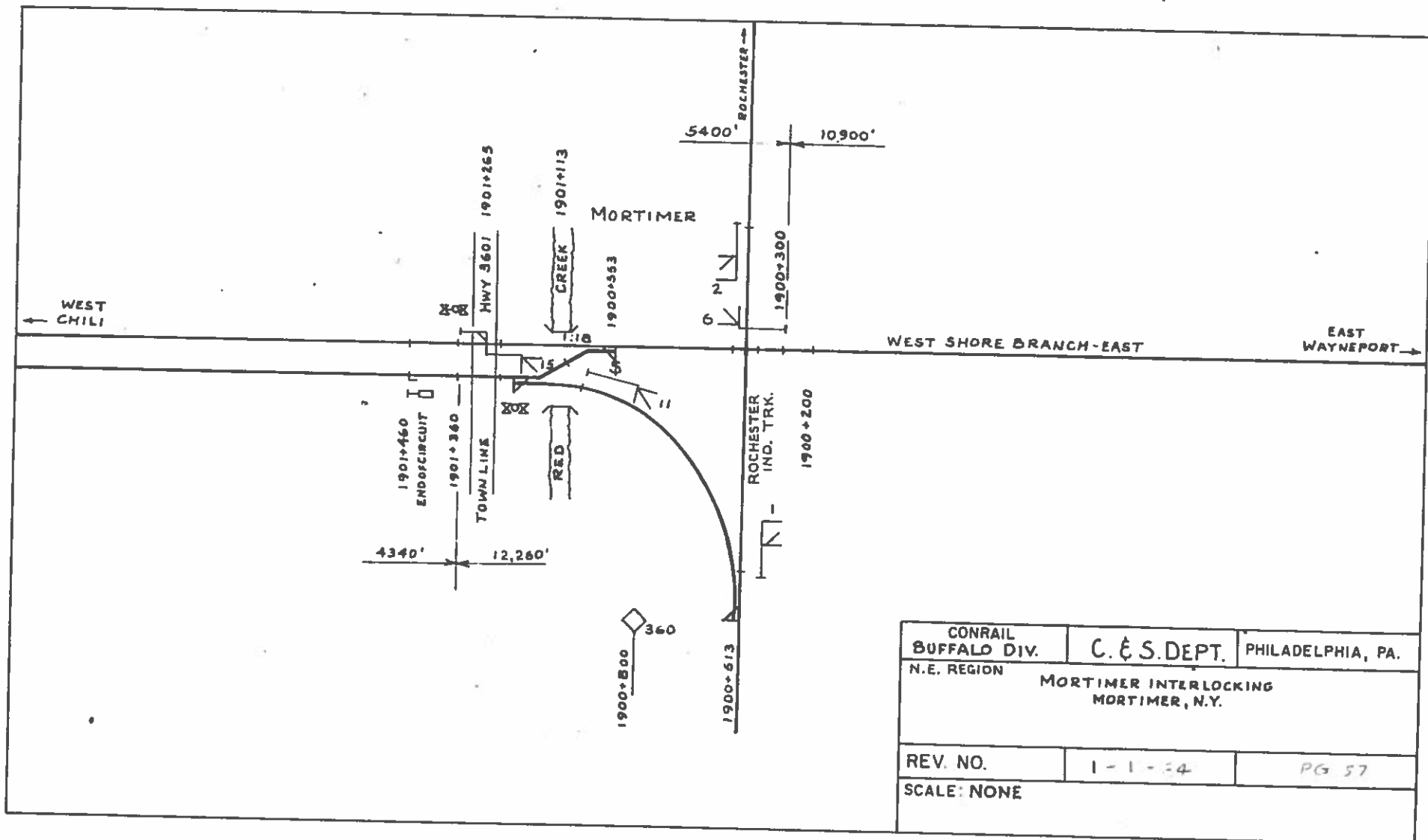

CONRAIL BUFFALO DIV. N.E. REGION	C. & S. DEPT.	PHILADELPHIA, PA.
--	---------------	-------------------

MORTIMER INTERLOCKING
MORTIMER, N.Y.

REV. NO.	1-1-34	PG 57
----------	--------	-------

SCALE: NONE

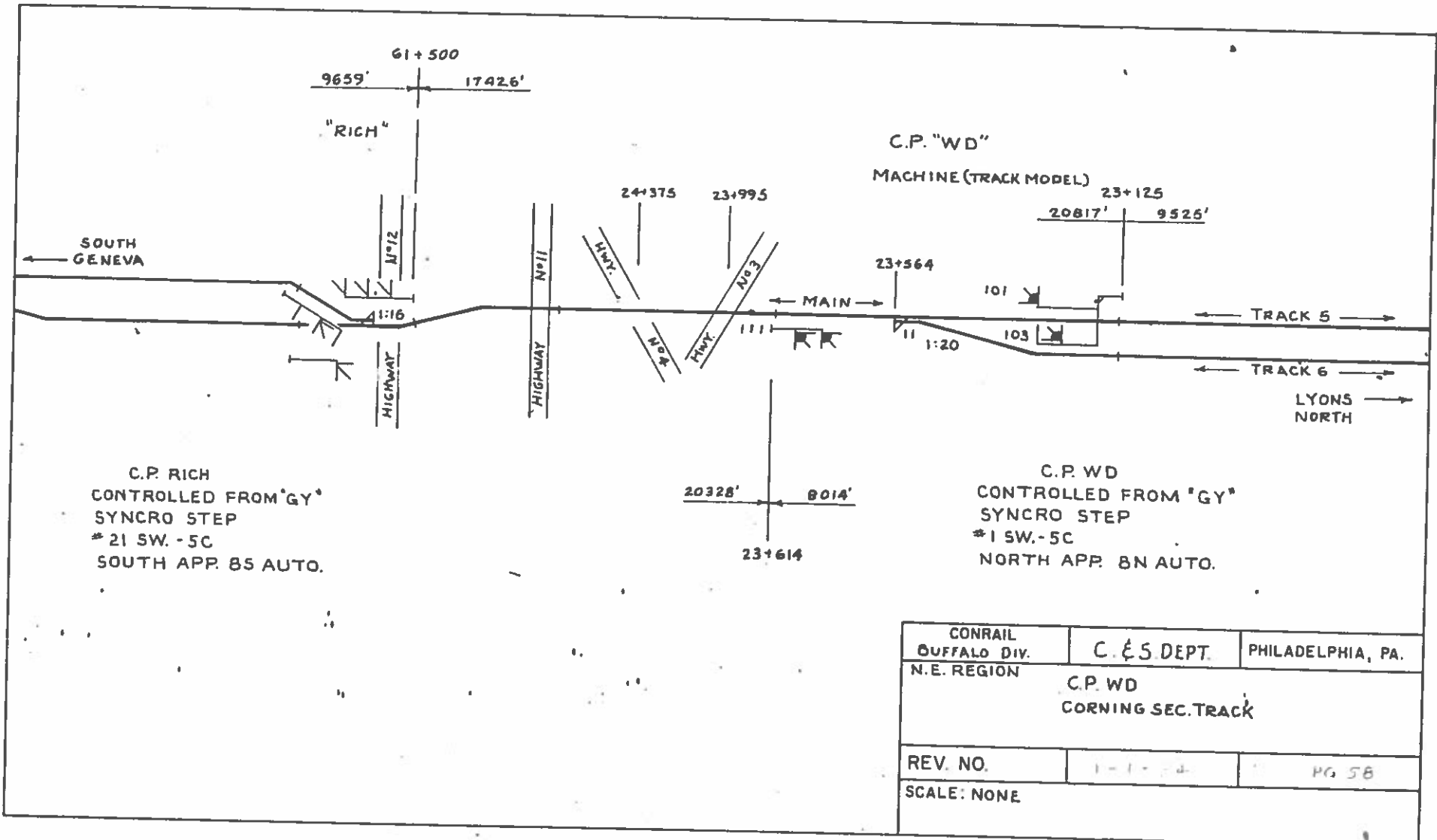

C.P. RICH
 CONTROLLED FROM "GY"
 SYNCRO STEP
 # 21 SW. - 5C
 SOUTH APP. 85 AUTO.

C.P. WD
 CONTROLLED FROM "GY"
 SYNCRO STEP
 # 1 SW. - 5C
 NORTH APP. 8N AUTO.

CONRAIL BUFFALO DIV. N.E. REGION	C. & S. DEPT.	PHILADELPHIA, PA.
C.P. WD CORNING SEC. TRACK		
REV. NO.	1-1-24	PG 58
SCALE: NONE		

C.P. 79
CAMBRIA, N.Y.

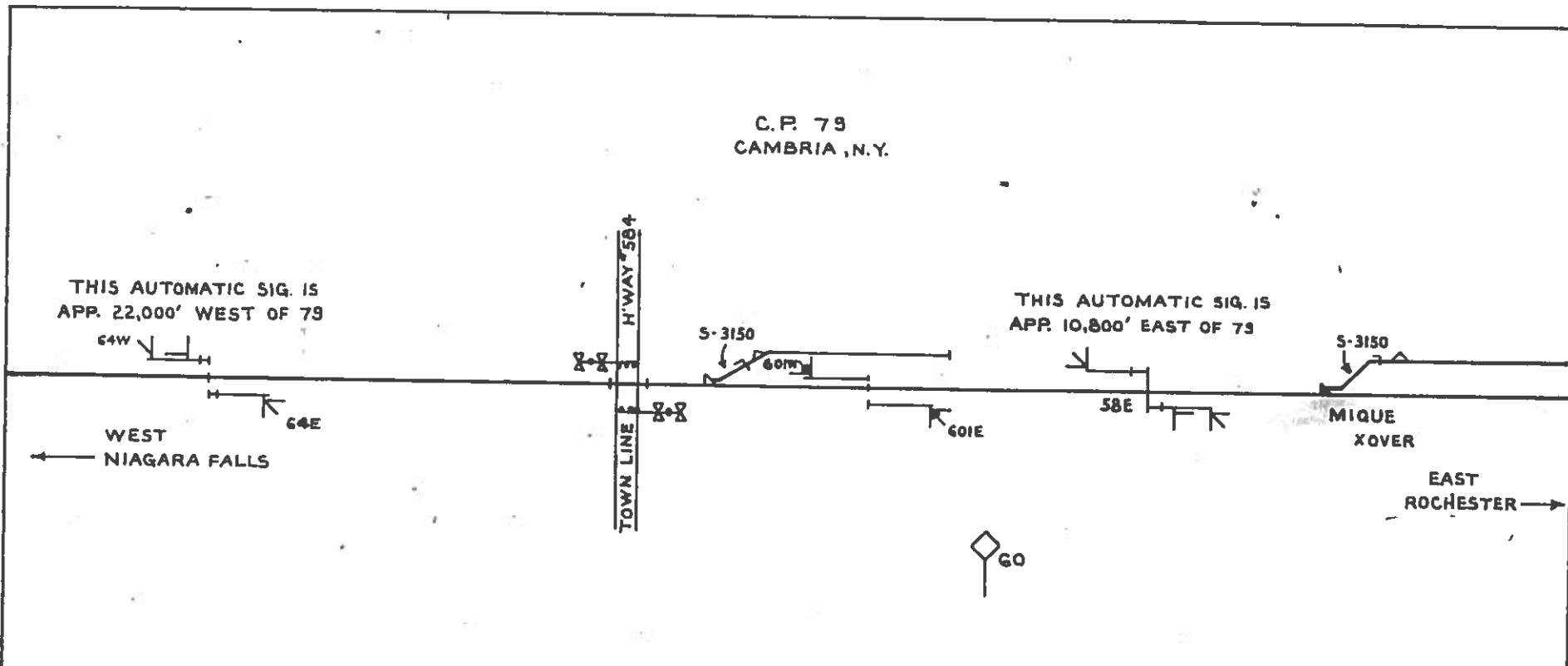

CONRAIL BUFFALO DIV. N.E. REGION	COMM. & SIGNALS	PHILADELPHIA, PA.
C.P. 79 FALLS ROAD BR. CAMBRIA, N.Y.		
REV. NO.	1-1-84	PG 59
SCALE: NONE		
NEW PLAN DRAWN - 5-21-8		VAB

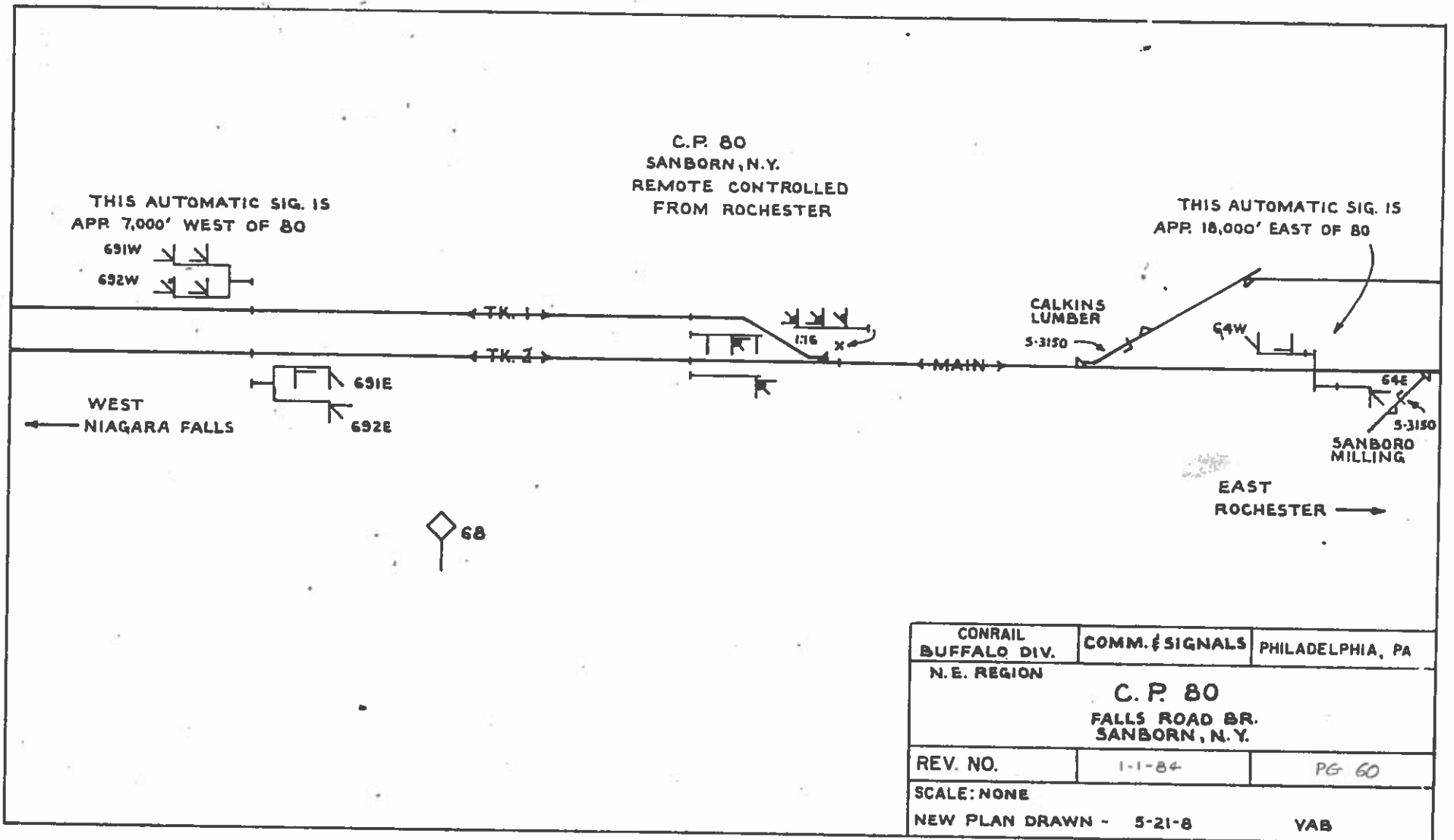

CONRAIL BUFFALO DIV.	COMM. & SIGNALS	PHILADELPHIA, PA
N. E. REGION		
C. P. 80 FALLS ROAD BR. SANBORN, N. Y.		
REV. NO.	1-1-84	PG 60
SCALE: NONE		
NEW PLAN DRAWN - 5-21-8		YAB

SET BY 4510017 1000
 PR CRT PLAN NO. A-1027-C1
 (R.R. PLAN 6000-6345' (1-5) (129,5-9)

DATED BY R.E. BECKER
 USED BY R.R. BECKER & C. R. E.
 OPERATED BY THE R.R.
 MAINTAINED BY THE R.R.

PROPORTION OF FORTIFICATION
 REE. 50.00% 50.00%
 R.R. 50.00% 50.00%
 * In process of removal

CORRECT AS OF
 1-34

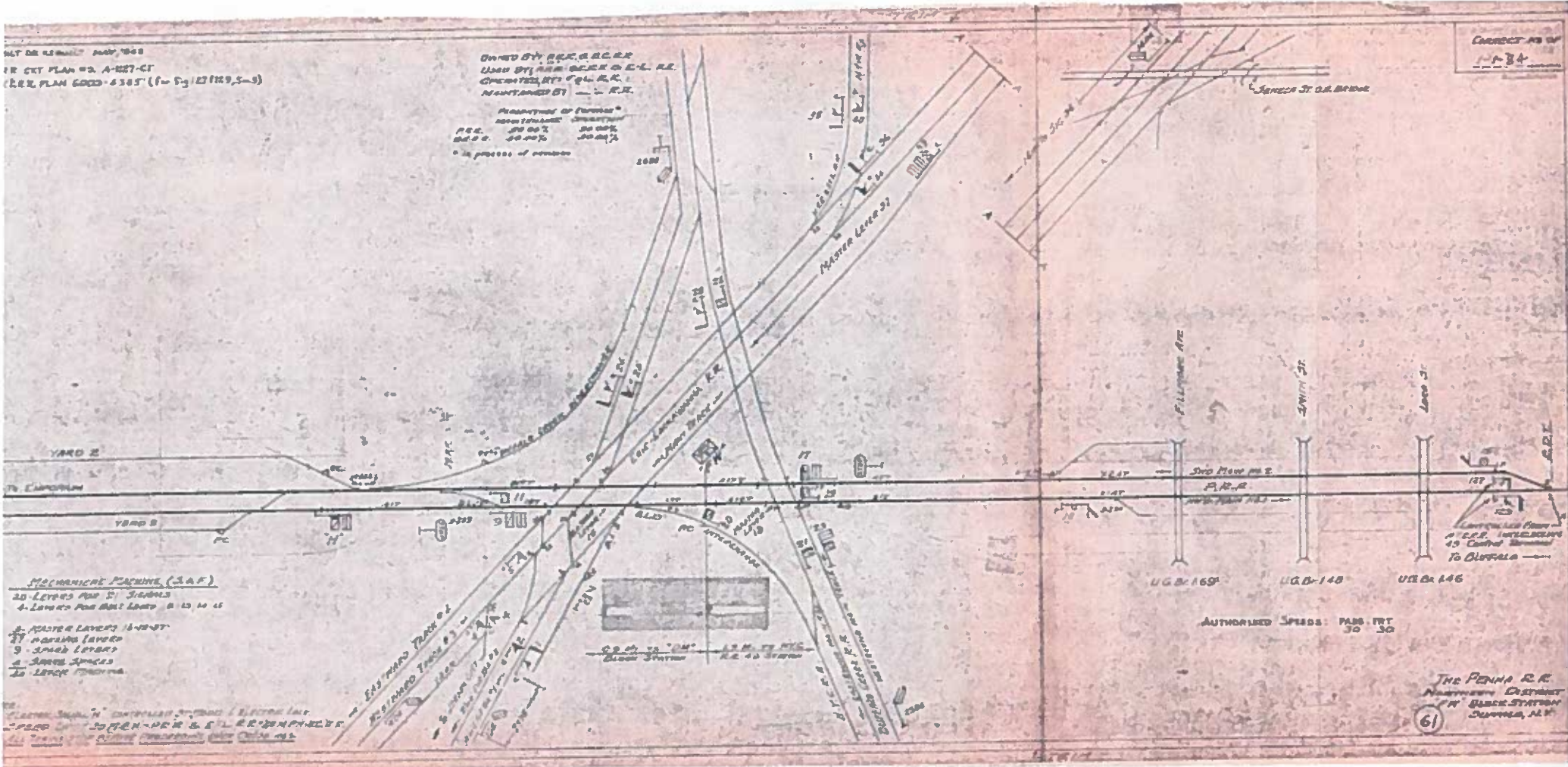

MECHANICAL ENGINE (S.A.F.)
 20 LEVELS FOR 2' STAIRS
 4 LEVELS FOR 2' STAIRS
 2 MASTER LEVELS 15-18-21
 1 WORKING LEVEL
 9 STAIR LEVELS
 4 STAIR SPACES
 20 LEVEL STAIRS

AUTHORIZED SPEEDS: PASSENGER 30 30

THE PENNA. R.R.
 MAINTENANCE DISTRICT
 IN BALTIMORE STATION
 BALTIMORE, MD.

61

BUILT ON EXISTING WORK, 1904
 SEE PLAN B-393-C

CORRECT AS OF
 1-1-24

OWNED BY - A.R.R. & L.R.
 USED BY - P.R.R. & L.R.
 OPERATED BY - P.R.R.
 MAINTAINED BY - L.R.

PERCENTAGE OF SERVICE

MAINTENANCE	OPERATION
A.R.R.	43.75%
L.R.	56.25%
	100%

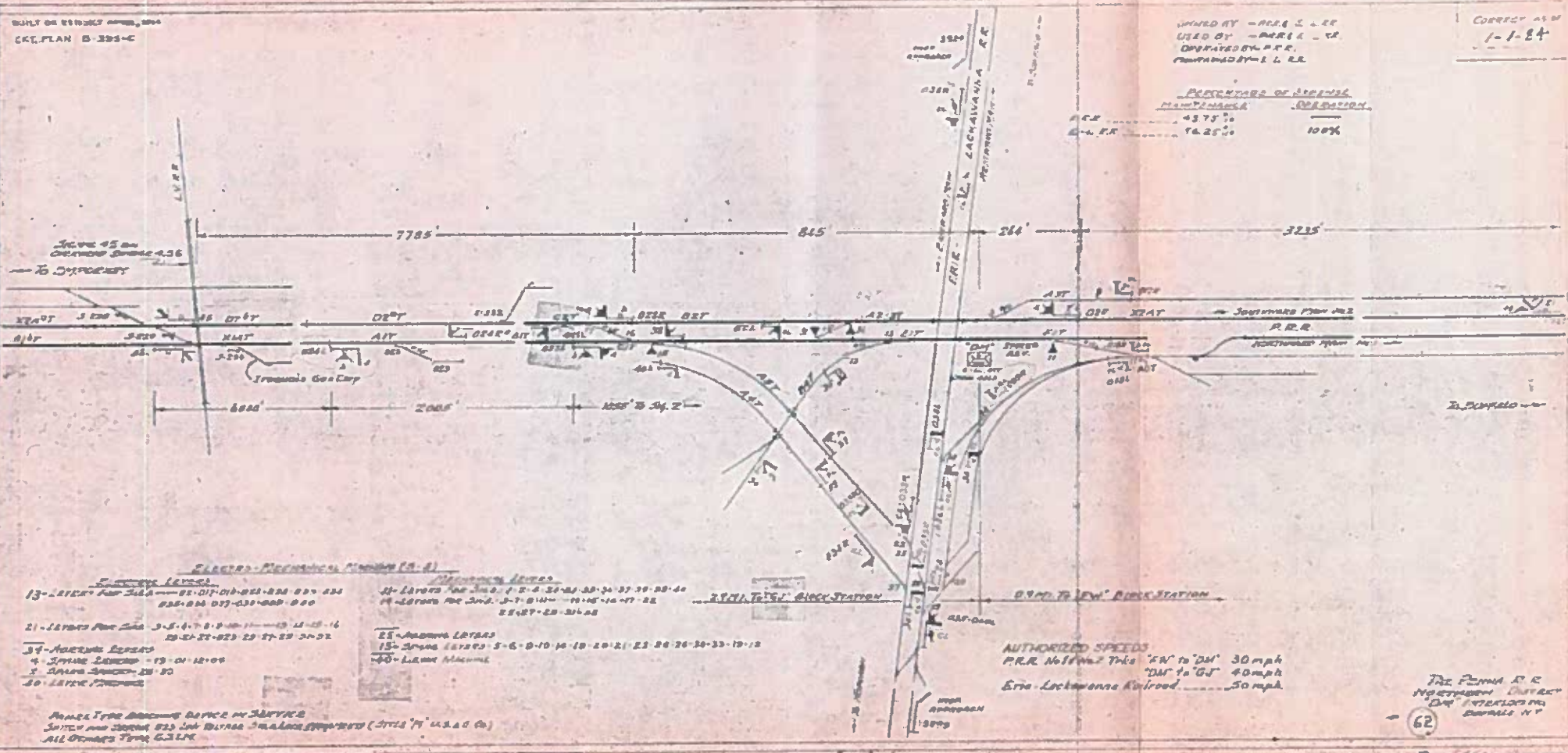

Electro-Mechanical Symbols (A-1)

- Signal Lenses**
- 13 - Lenses for 3145 - 01-07-08-09-10-11-12-13-14-15-16-17-18-19-20-21-22-23-24-25-26-27-28-29-30-31-32-33-34-35-36-37-38-39-40-41-42-43-44-45-46-47-48-49-50-51-52-53-54-55-56-57-58-59-60-61-62-63-64-65-66-67-68-69-70-71-72-73-74-75-76-77-78-79-80-81-82-83-84-85-86-87-88-89-90-91-92-93-94-95-96-97-98-99-100
 - 21 - Lenses for 2145 - 01-02-03-04-05-06-07-08-09-10-11-12-13-14-15-16-17-18-19-20-21-22-23-24-25-26-27-28-29-30-31-32-33-34-35-36-37-38-39-40-41-42-43-44-45-46-47-48-49-50-51-52-53-54-55-56-57-58-59-60-61-62-63-64-65-66-67-68-69-70-71-72-73-74-75-76-77-78-79-80-81-82-83-84-85-86-87-88-89-90-91-92-93-94-95-96-97-98-99-100
 - 34 - Lenses for 3445 - 01-02-03-04-05-06-07-08-09-10-11-12-13-14-15-16-17-18-19-20-21-22-23-24-25-26-27-28-29-30-31-32-33-34-35-36-37-38-39-40-41-42-43-44-45-46-47-48-49-50-51-52-53-54-55-56-57-58-59-60-61-62-63-64-65-66-67-68-69-70-71-72-73-74-75-76-77-78-79-80-81-82-83-84-85-86-87-88-89-90-91-92-93-94-95-96-97-98-99-100
 - 4 - Signal Lenses - 19-01-12-09
 - 5 - Signal Lenses - 28-30
 - 20 - Lenses for 2045

- Signal Lenses**
- 14 - Lenses for 1445 - 01-02-03-04-05-06-07-08-09-10-11-12-13-14-15-16-17-18-19-20-21-22-23-24-25-26-27-28-29-30-31-32-33-34-35-36-37-38-39-40-41-42-43-44-45-46-47-48-49-50-51-52-53-54-55-56-57-58-59-60-61-62-63-64-65-66-67-68-69-70-71-72-73-74-75-76-77-78-79-80-81-82-83-84-85-86-87-88-89-90-91-92-93-94-95-96-97-98-99-100
 - 25 - Lenses for 2545 - 01-02-03-04-05-06-07-08-09-10-11-12-13-14-15-16-17-18-19-20-21-22-23-24-25-26-27-28-29-30-31-32-33-34-35-36-37-38-39-40-41-42-43-44-45-46-47-48-49-50-51-52-53-54-55-56-57-58-59-60-61-62-63-64-65-66-67-68-69-70-71-72-73-74-75-76-77-78-79-80-81-82-83-84-85-86-87-88-89-90-91-92-93-94-95-96-97-98-99-100
 - 15 - Signal Lenses - 5-6-8-10-14-18-20-21-23-26-28-30-33-35-38
 - 40 - Lenses for 4045

AUTHORIZED SPEEDS
 P.R.R. Notwithstanding 'EN' to 'DM' 30 mph
 'DM' to 'GT' 40 mph
 Erie-Lackawanna Railroad 50 mph

The Penna. R. & N.Y. Co. is not responsible for any errors or omissions in this plan.
 62

Signal Type Drawing Office at Service
 Signal and Switching Signal Symbols (Title 'A' U.S.A. Co.)
 All Symbols from G.S.P.M.